

HELICAL-MULTIPLIER SERIES REDUCER

Use alone as either a speed reducer or increaser or in combination with a 700 Series worm gear reducer to create an efficient right angle double reduction speed reducer.



Non-Flanged



Flanged

- Close grained cast iron housing and flanges
- Hardened steel helical gearing for long life
- Anti-friction bearings
- Double lip seals guard against oil leakage
- Brass spring loaded breather plug keeps out dirt and water
- Optional steel bolt on base
- Double bearing design on input and output shaft

Optional Base Kits		
Unit Size	Catalog Description	Item Code
1	HM1 Base Kit	83501
2	HM2 Base Kit	83502
3	HM3 Base Kit	83503

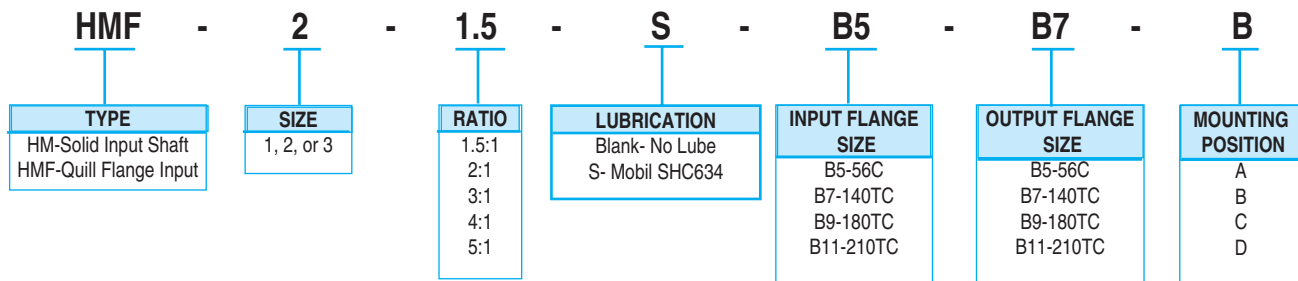

Available Styles

Model	Input	Output
HM1	Solid	B5
HMF1	B5	B5
HM2	Solid	B5
		B7
HMF 2	B5	B5
	B5	B7
	B7	B5
	B7	B7

Model	Input	Output
HM3	Solid	B9
		B11
HMF3	B9	B9
	B9	B11
	B11	B9
	B11	B11

HELICAL-MULTIPLIER SERIES REDUCER

Reductor Models

Catalog Number	Item Code
HM1-1.5-B5	83205
HM1-2-B5	83206
HM1-3-B5	83207
HM1-4-B5	83208
HM1-5-B5	83209
HM2-1.5-B7	83210
HM2-1.5-B5	83211
HM2-2-B7	83212
HM2-2-B5	83213
HM2-3-B7	83214
HM2-3-B5	83215
HM2-4-B7	83216
HM2-4-B5	83217
HM2-5-B7	83218
HM2-5-B5	83219
HM3-1.5-B9	83220
HM3-1.5-B11	83221
HM3-2-B9	83222
HM3-2-B11	83223
HM3-3-B9	83224
HM3-3-B11	83225
HM3-4-B9	83226
HM3-4-B11	83227
HM3-5-B9	83228
HM3-5-B11	83229

NEMA C-Face Models

Catalog Number	Item Code
HMF1-1.5-B5-B5	76600
HMF1-2-B5-B5	83230
HMF1-3-B5-B5	76602
HMF1-4-B5-B5	83231
HMF1-5-B5-B5	83232
HMF2-1.5-B7-B7	76620
HMF2-1.5-B7-B5	76615
HMF2-1.5-B5-B7	76610
HMF2-1.5-B5-B5	76605
HMF2-2-B7-B7	83233
HMF2-2-B7-B5	76616
HMF2-2-B5-B7	76611
HMF2-2-B5-B5	83234
HMF2-3-B7-B7	83235
HMF2-3-B7-B5	76617
HMF2-3-B5-B7	76612
HMF2-3-B5-B5	76607
HMF2-4-B7-B7	83236
HMF2-4-B7-B5	76618
HMF2-4-B5-B7	83237
HMF2-4-B5-B5	83238
HMF2-5-B7-B7	83239
HMF2-5-B7-B5	76619
HMF2-5-B5-B7	83240
HMF2-5-B5-B5	83241
HMF3-1.5-B9-B9	76625
HMF3-1.5-B9-B11	76630
HMF3-1.5-B11-B9	76635
HMF3-1.5-B11-B11	76640
HMF3-2-B9-B9	76626
HMF3-2-B9-B11	76631
HMF3-2-B11-B9	83242
HMF3-2-B11-B11	76641
HMF3-3-B9-B9	76627
HMF3-3-B9-B11	76632
HMF3-3-B11-B9	76637
HMF3-3-B11-B11	76642
HMF3-4-B9-B9	83243
HMF3-4-B9-B11	76633
HMF3-4-B11-B9	76638
HMF3-5-B9-B9	83244
HMF3-5-B9-B11	76634
HMF3-5-B11-B9	76639
HMF3-5-B11-B11	83245

HELICAL MULTIPLIER LUBRICATION

Horizontal Mounting

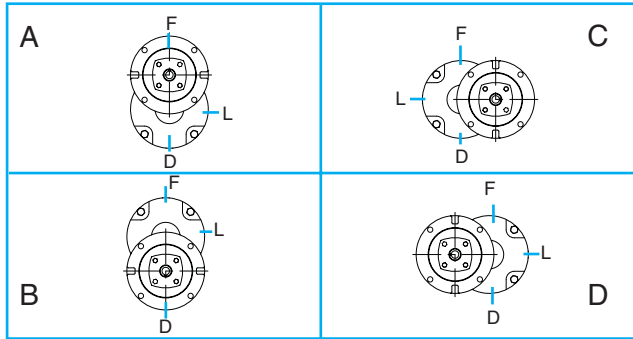

Vertical Mounting

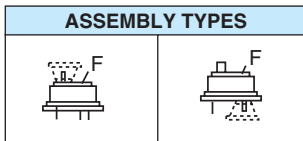

Recommended Lubricants

The following tables indicate the type and viscosity of lubricant suitable for reducers operating at various temperatures.

Lubrication and maintenance instructions are provided with each speed reducer. These instructions should be followed for best results. It is important that the proper type of oil be used since many oils are not suitable for the lubrication of gears. Various types of gearing require different types of lubricants.

The lubricant must remain free from oxidation and contamination by water or debris since only a very thin film of oil stands between efficient operation and failure. To assure long service life, the reducer should be periodically drained (preferably while warm) and refilled to the proper level with a recommended gear oil. Under normal environmental conditions oil changes, are suggested after the initial 250 hours of operation, and thereafter, at regular intervals of 2500 hours or every 6 months. Synthetic lubricants will allow extended lubrication intervals due to its increased resistance to thermal and oxidation degradation. It is suggested that the initial oil change be made at 1500 hours and, thereafter, at 5000 hour intervals.

During the initial period of operation, higher than normal operating temperatures may be seen. This is due to the initial break-in of the gear set. The temperature of Helical Gear Reducers may reach 160°F.

Enclosed Helical

Ambient (Room) Temperature	Recommended Oil (or equivalent)	Viscosity Range S&S @ 100°F	Lubricant AGMA No.	ISO Viscosity Grade No.
-30° to 225°F ‡ (-34°C to 107°C)	Mobil SHC634* Synthetic	1950/2150	—	320/460
20° to 60°F (-6.7°C to 15.5°C)	Mobil D.T.E. Oil Heavy Medium	315/355	2 or 2EP	68
50° to 125°F (10°C to 51.7°C)	Mobil D.T.E. Oil Extra Heavy	710/790	4 or 4EP	150

Recommended Lubricant	Boston Gear Item Code	
	Quart	Gallon
Mobil SHC634	51493	51494

CAUTION: Relubricate more frequently, if drive is operated in high ambient temperatures or unusually contaminated atmospheres. High loads and operating temperatures will also require more frequent relubrication.

*Synthetic recommendation is exclusively for Mobil SHC634.

‡The SHC lubricant will perform at temperatures considerably higher than 225°F. However, the factory should always be consulted prior to operating at higher temperatures, as damage may occur to oil seals and other components.

Drain Plug must be installed in the lower most location of the housing. This plug will be on the input shaft side of the housing for positions B, C, D and A. may be either side for A.

The **Vented Filler Plug** should be installed in the uppermost location. This plug will be on the input shaft side for positions A, C, or D, on either side for B and must be tightened into position.

Level Plug position will be as indicated for horizontal positions. For vertical positions the oil level is established by an oil level distance measured from the outer surface of the housing from the oil filler hole.

Size	Flanged		Non-Flanged	
	Weight (lbs.)	Capacity (Ozs)	Weight (lbs.)	Capacity (Ozs)
1	18	11	14	11
2	25	14	21	14
3	50	28	43	28

INSTALLATION, LUBRICATION and OPERATION INSTRUCTIONS

Warning: *Boston Gear speed reducers are normally shipped without lubricant. They must be filled to the proper level with the recommended lubricant before operation.*

These instructions must be read thoroughly before installing or operating speed reducers. File instructions for future reference

CAUTION

- For safe operation of any gear drive, all rotating shafts and auxiliary components must be shielded to conform with applicable safety standards. You must consider overall operational system safety at all times.
- When using a gear drive to raise or lower a load, such as in hoisting applications, provision must be made for external braking. Under no conditions should a speed reducer be considered self-locking.
- Mounting of speed reducers in overhead positions may be hazardous. Use of external guides or supports is strongly recommended for overhead mounting.

General Instructions

1. When mounting, use maximum possible bolt size and secure gear drive to a rigid foundation. Periodic inspection of all bolts is recommended.
2. Align all shafts accurately. Improper alignment can result in failure. Use of flexible couplings is recommended to compensate for slight misalignment.
3. Arrange the drain and breather plug per your mounting position as indicated on page 9. The breather plug should also be located in the *Fill* position.
4. Auxiliary drive components (such as sprockets, gears and pulleys) should be mounted on the shafts as close as possible to the housing to minimize effects of overhung loads. Avoid force fits that might damage bearings or gears.
5. Gear drives are nameplated for 1750 RPM Input Speed and Class I Service. For lower Input Speeds

and other Service Class, refer to catalog rating information.

6. Input Speeds of 1750 and lower are shown in catalog rating tables for speed reducing applications. This does not represent the maximum speed. Since speed limitation is based on pitching velocity and varies with size and ratio.

Instructions for Flanged Models

HMF (Quill Type Input)

1. Assemble the key to the motor shaft and coat the shaft with anti-seize compound. Insert the motor shaft into the reducer input shaft.
2. Rotate the motor to proper position and firmly secure to flange with four hex-head cap screws.

CAUTION - If the motor does not readily seat itself, check to determine if key has moved axially along motor shaft, causing interference. Staking of the keyway adjacent to the motor key will facilitate this procedure.

Location of Filler, Level and Drain Plugs

Helical-Multiplier reducers may be mounted in any position shown.

Filler, level and drain plugs are completely interchangeable and should be arranged to suit the required mounting positions.

HELICAL MULTIPLIER SERIES RATIO & CAPACITY SELECTION TABLES

HORSEPOWER AND TORQUE CAPACITIES (SERVICE FACTOR 1.0)

SERIES SIZE			HM SIZE 1			HM SIZE 2			HM SIZE 3		
RATIO	INPUT RPM	OUTPUT RPM	INPUT HP	OUTPUT		INPUT HP	OUTPUT		INPUT HP	OUTPUT	
				HP	TORQUE (Lb. In.)		HP	TORQUE (Lb. In.)		HP	TORQUE (Lb. In.)
1.5	1750	1167	3.29	3.19	172	13.60	13.19	712	17.79	17.26	932
2	1750	875	2.74	2.66	192	11.76	11.41	822	15.38	14.92	1075
3	1750	583	2.06	2.00	216	9.48	9.20	944	12.39	12.02	1299
4	1750	437	1.45	1.41	203	6.88	6.67	962	8.99	8.72	1258
5	1750	350	1.05	1.02	183	5.06	4.91	884	6.61	6.41	1155

Output Shaft Thrust Rating (lbs.)

	1.5:1	2:1	3:1	4:1	5:1
HM1	153	169	193	213	230
HM2	230	253	289	319	345
HM3	313	345	394	435	470

Overhung Loads (lbs.)

	HM size 1	HM Size 2		HM Size 3	
Input	200	200		350	
Output	315	B5 375	B7 750	B9 1100	B11 1135

RATINGS SHOWN REFLECT MAXIMUM GEAR CAPACITY WITH MOBIL SHC 634 LUBRICANT.

Overhung Load is at centerline of output shaft projection and with NO THRUST Load.

HELICAL MULTIPLIER SERIES REDUCER DIMENSIONS

HM Basic

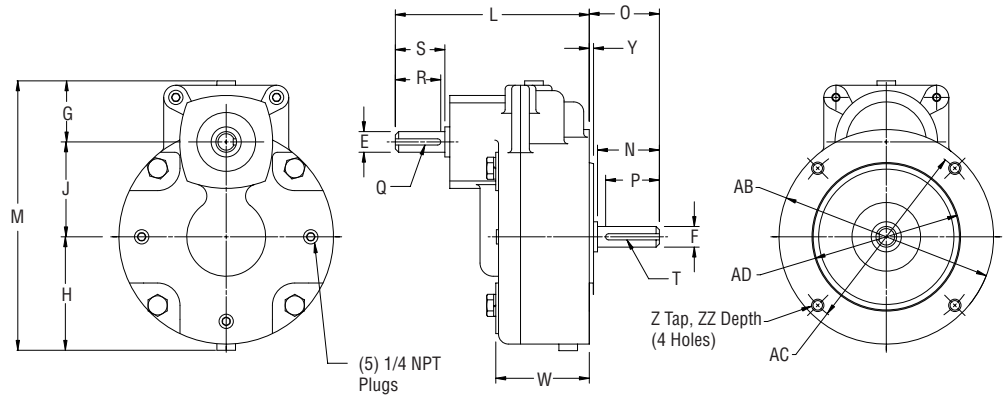

HM with Base

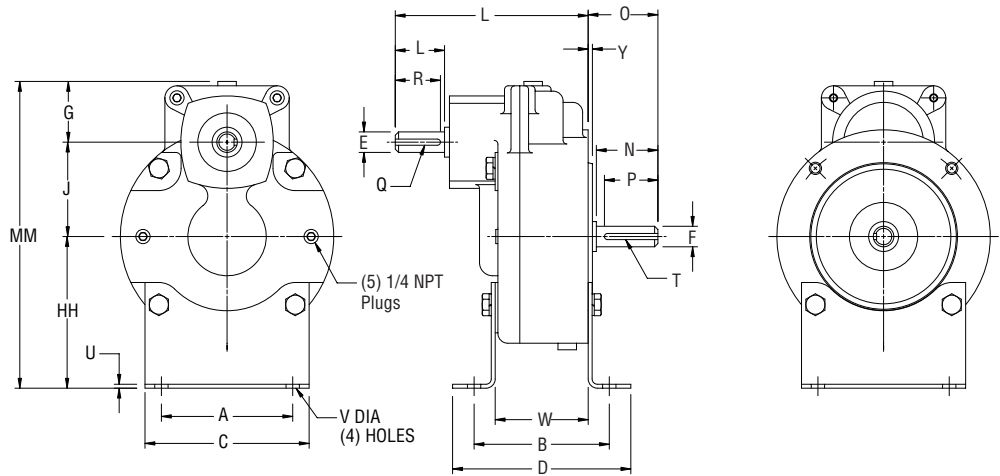

ALL DIMENSIONS IN INCHES

Size	Output Flange	A	B	C	D	E	F	G	H	HH	J	L	M	MM	N	O	P
1	56C	4.00	3.875	5.00	5.187	0.625	0.625	1.805	3.45	4.62	1.675	5.375	6.875	8.100	1.875	2.06	1.625
2	56C						0.625										
	140TC	4.00	4.120	5.00	5.430	0.625	0.875	1.850	3.40	4.62	2.875	5.875	8.15	9.350	1.875	2.125	1.625
3	180TC						1.125								2.375	2.50	2.063
	210TC	5.13	4.750	6.37	6.150	0.875	1.375	2.087	4.70	4.81	2.875	8.00	9.66	9.77	2.875	3.00	2.563

Size	Output Flange	Q	R	S	T	U	V	W	Y	Z	ZZ	AB	AC	AD
1	56C	3/16X3/32	1.375	1.50	3/16X3/32	0.12	0.406	2.59	0.13	3/8-16	0.75	6.50	5.875	4.50
2	56C				3/16X3/32									
	140TC	3/16X3/32	1.375	1.50	3/16X3/32	0.12	0.406	2.83	0.13	3/8-16	0.75	6.50	5.875	4.50
3	180TC				1/4X1/8									
	210TC	3/16X3/32	1.750	2.00	5/16X5/32	0.16	0.500	3.24	0.25	1/2-13	0.94	9.13	7.250	8.50

HELICAL MULTIPLIER SERIES REDUCER DIMENSIONS

HMF Basic

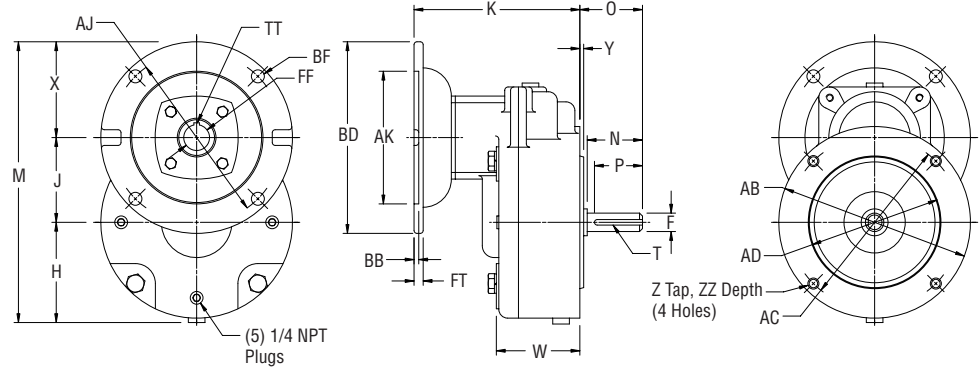

HMF with Base

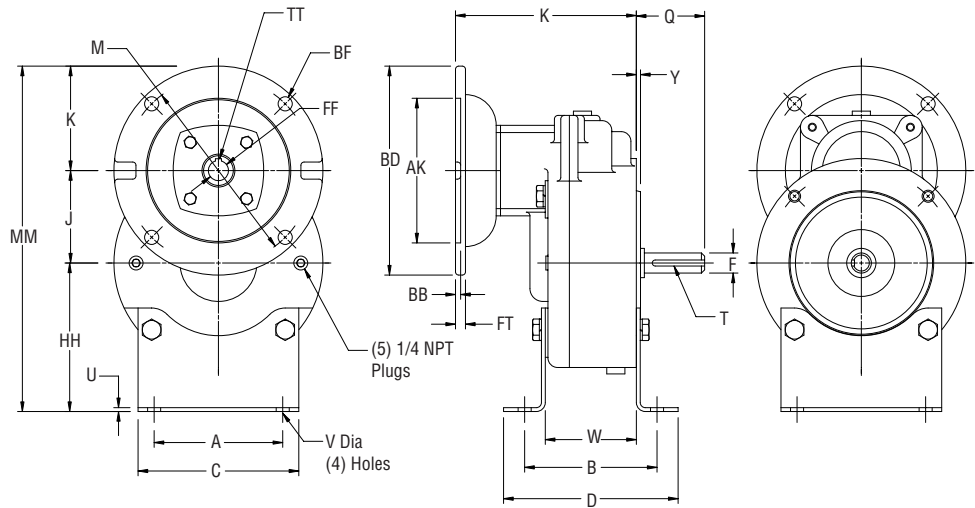

ALL DIMENSIONS IN INCHES

Size	Output Flange	A	B	C	D	F	H	HH	J	K	M	MM	N	O	P	T
1	B5	4.00	3.875	5.00	5.187	0.625	3.45	4.62	1.675	5.177	8.38	9.55	1.875	2.06	1.625	3/16X3/32
2	B5	4.00	4.120	5.00	5.430	0.625	3.40	4.62	2.875	5.625	9.53	10.75	1.875	2.125	1.625	3/16X3/32
	0.875															
3	B9	5.13	4.750	6.37	6.150	1.125	4.70	4.81	2.875	7.43	12.08	12.19	2.375	2.50	2.063	1/4X1/8
	1.375					2.875							3.00			2.563

Size	U	V	W	X	Y	Z	ZZ	AB	AC	AD
1	0.12	0.406	2.59	3.25	0.13	3/8-16	0.75	6.50	5.875	4.50
2	0.12	0.406	2.83	3.25	0.13	3/8-16	0.75	6.50	5.875	4.50
3	0.16	0.500	3.24	4.50	0.25	1/2-13	0.94	9.13	7.250	8.50

Size	Input Flange	AJ	AK	BD	BF	BB	FF	FT	TT
1	B5	5.875	4.50	6.50	0.44	0.16	0.625	0.31	3/16x3/32
2	B5	5.875	4.50	6.50	0.44	0.16	0.625	0.31	3/16x3/32
	B7	5.875	4.50	6.50	0.44	0.16	0.875	0.31	3/16x3/32
3	B9	7.250	8.50	9.00	0.53	0.19	1.125	0.38	1/4x1/8
	B11	7.250	8.50	9.00	0.53	0.19	1.375	0.38	5/16x5/32