









## SECTION CONTENTS

PRODUCT REFERENCE GUIDE .....	134
NUMBERING SYSTEM/HOW TO ORDER.....	135
INTERCHANGE AND SELECTION PROCEDURE .....	136-138
MOUNTINGS .....	139
LUBRICATION .....	140
OVERHUNG LOAD/WEIGHTS.....	141
OUTPUT RPM SELECTION TABLES.....	142-158
REDUCER RATINGS.....	159-168
DIMENSIONS .....	169-176

## 800 SERIES INLINE HELICAL GEAR DRIVES

<p><b>F800B Series In-Line Helical Gear Flanged Input</b></p>	<p>Double Reduction Foot Mounted, Flange Input</p>  <p>Selection Pages 142-158 Dimensions-Page 169</p>	<p>Triple Reduction Foot Mounted, Flange Input</p>  <p>Selection Pages 142-158 Dimensions-Page 170</p>
	<p>Double Reduction Output Flange Mount, Flange Input</p>  <p>Selection Pages 142-158 Dimensions-Page 171</p>	<p>Triple Reduction Output Flange Mount, Flange Input</p>  <p>Selection Pages 142-158 Dimensions-Page 172</p>
	<p>Double Reduction Foot Mounted</p>  <p>Selection Pages 159-168 Dimensions-Page 173</p>	<p>Triple Reduction Foot Mounted</p>  <p>Selection Pages 159-168 Dimensions-Page 174</p>
	<p>Double Reduction Output Flange Mount</p>  <p>Selection Pages 159-168 Dimensions-Page 175</p>	<p>Triple Reduction Output Flange Mount</p>  <p>Selection Pages 159-168 Dimensions-Page 176</p>

# 800 SERIES IN-LINE HELICAL GEAR DRIVES

## NUMBERING SYSTEM / HOW TO ORDER

### NUMBERING SYSTEM

#### EXAMPLE:

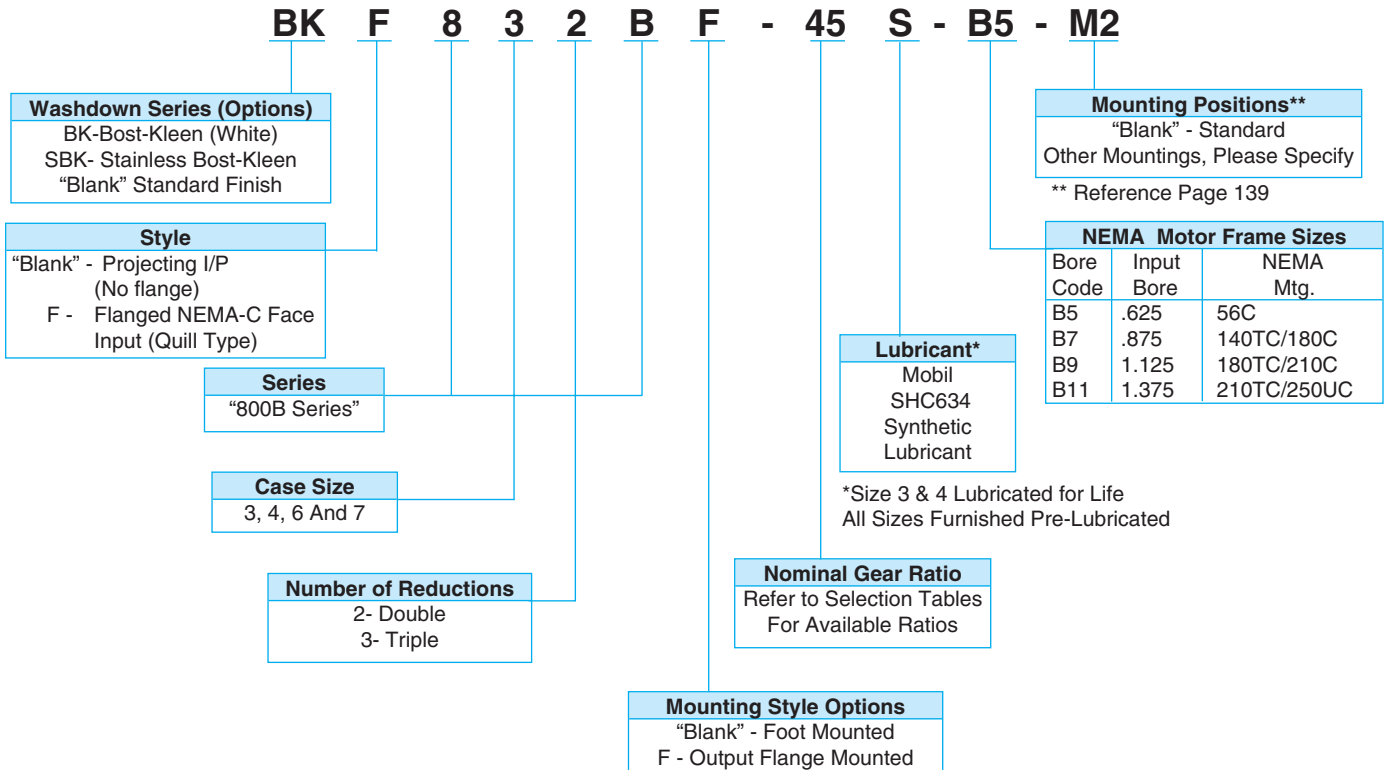

### HOW TO ORDER

#### EXAMPLE:

Required flange input NEMA 56C, and flanged output, 1/3 HP, Class I, 45:1 ratio, lubricated, and standard mounting position.

Order:

1 pc F832BF-45S-B5 or 5 digit item code 22662

# 800 SERIES IN-LINE HELICAL GEAR DRIVES

## INTERCHANGE GUIDE

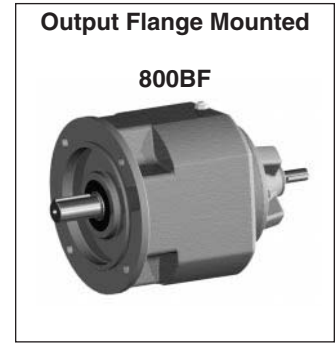

Boston Gear 800 Series In-Line Helical Gear Drives are designed to be functionally interchangeable with these and many other manufacturer's drives. This chart is intended to be a guide only. Please see appropriate manufacturer's catalogs for exact details regarding ratings and dimensions.

Manufacturers	Size	Foot Mounted NEMA C-Face F800B	Foot Mounted 800B	Output Flange Mounted NEMA C-Face F800BF	Output Flange Mounted 800BF
Boston	830	F832B/F833B	832B/833B	F832BF/F833BF	832BF/833BF
SEW Eurodrive	32	R32LP	Not Available	RF32LP	Not Available
Dodge (Quantis)		Not Available	Not Available	Not Available	Not Available
Falk	03	03UCBN2(3)-A	03UCBN2(3)-N	03UCFN2(3)-A	03UCFN2(3)-N
David Brown	M03	M032(3)BAN	M032(3)BRN	M032(3)FAN	M032(3)FRN
Flender	E20*	E20 (M, G, OR A)*	E20A*	EF20 (M, G OR A)*	EF20A*
Sumitomo	3090	H (C or M) 3090/95/97	H3090/95/97	HF(C or M) 3090/95/97	HF3090/95/97
Stober	C002	C002N-MR	C002N-AW	C002F-MR	C002F-AW
Nord	02	SK02	SK02-W	SK02F	SK02-W
Boston	840	F842B/F843B	842B/843B	F842BF/F843BF	842BF/843BF
SEW Eurodrive	40	R40LP	R40	RF40LP	RF40
Dodge (Quantis)	38	HB382(3)CN	Not Available	HB382(3)CN	Not Available
Falk	04	04UCBN2(3)-A	04UCBN2(3)-N	04UCFN2(3)-A	04UCFN2(3)-N
David Brown	M04	M042(3)BAN	M042(3)BRN	M042(3)FAN	M042(3)FRN
Flender	30	E30/Z30/D30-(M, G, or A)	E30/Z30/D30	EF30/ZF30/DF30 (M, G or A)	EF30/ZF30/DF30
Sumitomo	3100	H(C or M) 3100/05	H3100/05	HF(C or M) 3100/05	HF3100/05
Stober	C100	C102/3N-MR	C102/3N-AW	C102/3F-MR	C102/3F-AW
Nord	12	SK12(3)	SK12(3)-W	SK12(3)F	SK12(3)F-W
Boston	860	F862B/F863B	862B/863B	F862BF/F863BF	862BF/863BF
SEW Eurodrive	60	R60LP/R63LP	R60/R63	RF60LP/RF63LP	RF60/RF63
Dodge (Quantis)	48	HB482(3)CN	Not Available	HB482(3)CN	Not Available
Falk	06	06UCBN2(3)-A	06UCBN2(3)-N	06UCFN2(3)-A	06UCFN2(3)-N
David Brown	M06	M062(3)BAN	M062(3)BRN	M062(3)FAN	M062(3)FRN
Flender	40	E40/Z40/D40-(M, G or A)	E40/Z40/D40	EF40/ZF40/DF40-(M, G or A)	EF40/ZF40/DF40
Sumitomo	3110	H(C or M) 3110/15	H3110/15	HF(C or M) 3110/15	HF3110/15
Stober	C200	C202/3N-MR	C202/3N-AW	C202/3F-MR	C202/3F-AW
Nord	22	SK22	SK22(3)-W	SK22(3)F	SK22(3)F-W
Boston	870	F872B/F873B	872B/873B	F872BF/F873BF	872BF/873BF
SEW Eurodrive	70	R70LP/R73LP	R70/R73	RF70LP/RF73LP	RF70/RF73
Dodge (Quantis)	68	HB682(3)CN	Not Available	HB682(3)CN	Not Available
Falk	07	07UCBN2(3)-A	07UCBN2(3)-N	07UCFN2(3)-A	07UCFN2(3)-N
David Brown	M07	M072(3)BAN	M072(3)BRN	M072(3)FAN	M072(3)FRN
Flender	60	E60/Z60/D60 - (M, D or A)	E60/Z60/D60	EF60/ZF60/DF60 (M, D or A)	EF60/ZF60/DF60
Sumitomo	3140	H(C or M) 3140/45	H3140/45	HF(C or M) 3140/45	HF3140/45
Stober	C400	C402/3N-MR	C402/3N-AW	C402/3F-MR	C402/3F-AW
Nord	32	SK32(3)	SK32(3)-W	SK32(3)F	SK32(3)F-W

\* Single reduction models only.

If you require assistance with an interchange, please contact our customer service department at 1-888-999-9860.

**BOSTON GEAR®**

# 800 SERIES IN-LINE HELICAL GEAR DRIVES

## MOTORIZED GEAR DRIVES

1. Determine application service factor from page 138, or from Application Classifications on pages 344 and 345.
2. Determine output speed required.
3. Determine HP or output torque requirement.
4. Select a speed reducer size based on output speed and horsepower requirement for given service class.
5. Check overhung load calculation.

## EXAMPLE

Select an In-line motorized helical gear drive and motor to drive a uniformly loaded line conveyor 24 hours/day requiring 2 HP at 35 RPM.

### POWER REQUIREMENT

230/460 volt  
3 phase  
60 hertz

1. Select Service Factor Class from page 138.  
Service Class = II
2. Output RPM = 35
3. 2 HP
4. Select a 2 HP drive that will satisfy minimum of II service class.
5. O.H.L. = 1720 lbs. page 141
6. Order: 1 - F872B-50S-B7 (26494)  
1 - KUTF Motor Ref - page 329 for specific motor manufacturer.

Both a double and triple reduction gear drive is available. The double reduction will have an economic advantage. The triple reduction should be specified when relative rotation is of concern.

## OVERHUNG LOAD

If the output shaft of a gear drive is connected to the driven machine by other than a flexible coupling, an overhung load is imposed on the shaft. This load may be calculated as follows:

$$OHL = \frac{2TK}{D}$$

- OHL = Overhung Load (LB.)  
T = Shaft Torque (LB.-IN.)  
D = Pitch Diameter of Sprocket, Pinion or Pulley (IN.)  
K = Load Connection Factor

## LOAD CONNECTION FACTOR (K)

Sprocket or Timing Belt	1.00
Pinion and Gear Drive	1.25
Pulley and V-Belt Drive	1.50
Pulley and Flat Belt Drive	2.50

An overhung load greater than permissible load value may be reduced to an acceptable value by the use of a sprocket, pinion or pulley of a larger PD. Relocation of the load closer to the center of gear drive will also increase OHL capacity.

Permissible Overhung Loads and Output Shaft Thrust Loads are listed for each reducer in the Tables on Page 141.

## IN-LINE HELICAL SELECTION TABLES

## 1750 RPM INPUT

FOR RATINGS AT OTHER INPUT SPEEDS, SEE TABLES ON PAGES 159-168.

ORDER BY CATALOG NUMBER OR ITEM CODE  
FOR STANDARD MOUNTING POSITIONS

Approx. Output RPM	Ratio *	Non-Flanged				Flanged (Gearmotors)				
		Gear Capacity		Non-Flange O/P	Output Flange	Ratings			Non-Flange O/P	Output Flange
		Output Torque (LB-IN.)	Input HP	Catalog No. (Item Code)	Catalog No. (Item Code)	Motor HP	Output Torque (LB-IN.)	S.C. **	Catalog No. (Item Code)	Catalog No. (Item Code)
35	50	5216	3.16	872B-50S (16886)	872BF-50S (19813)	3	4900	I	F872B-50S-B9 (80863)	F872BF-50S-B9 (33806)
						2	3268	II	F872B-50S-B7 (26494)	F872BF-50S-B7 (33804)
		5290	3.02	873B-50S (16918)	873BF-50S (19937)	1.5	2552	III		
						3	5256	I	F873B-50S-B9 (30868)	F873BF-50S-B9 (27312)
						2	3504	II	F873B-50S-B7 (30866)	F873BF-50S-B7 (27294)

\* Gear Ratio is Approximate. For Actual Gear Ratio Reference Pages 159-168.

\*\* Service Class I (S.F. = 1.00) Service Class II (S.F. = 1.50) Service Class III (S.F. = 2.00)

Overhung Load Ratings refer to Page 141.

Indicates Triple Reduction

# 800 SERIES IN-LINE HELICAL GEAR DRIVES

To properly select a gear drive, the following application information should be known.

1. Service Factor or AGMA Service class.
2. Output Horsepower or Torque
3. Output RPM or Ratio  
(Maximum Input Speed 4500 RPM)

**NOTE:** The use of an auxiliary drive between the gear drive and the driven machine reduces the torque required at the output shaft in direct proportion to the auxiliary drive ratio.

A 3:1 chain ratio would reduce the torque requirement at the output shaft of the gear drive to one-third, resulting in a smaller unit size selection.

## NON-MOTORIZED GEAR DRIVES

1. Determine application service factor from the service factor chart on this page, or from Application Classifications on pages 344 and 345.
2. Determine design Horsepower or Torque.
  - Design HP = Application HP x S.F.
  - Design Torque = Application Torque x S.F.
3. Select a Gear drive that satisfies output RPM, service class and/or output torque requirement. Reference rating tables pages 159-168.
4. Overhung shaft load should be checked when belt or chain drives are used, to prevent premature shaft or bearing failure. Reference page 137 for calculations.

### EXAMPLE

Select an In-line 800 Series Gear Drive for a continuous duty concrete mixer requiring 700 lb-in. of torque at approx. 1000 RPM, to operate up to 8 hrs/day. The Gear Drive will be driven at 1450 input RPM.

1. Application Service Factor = 1.25
2. Design Torque = 700 x 1.25 = 875 LB-IN.
3. Select at speed and torque level of 875 LB-IN. or greater.
4. Order 862B1.5S.

## SERVICE FACTOR CHART

AGMA CLASS OF SERVICE	SERVICE FACTOR	OPERATING CONDITIONS
I	1.00	Moderate Shock-not more than 15 minutes in 2 hours Uniform Load-not more than 10 hours per day.
II	1.25	Moderate Shock-not more than 10 hours per day. Uniform Load-more than 10 hours per day.
	1.50	Heavy Shock-not more than 15 minutes in 2 hours. Moderate Shock-more than 10 hours per day.
III	1.75	Heavy Shock-not more than 10 hours per day.
	2.00	Heavy Shock-more than 10 hours per day.

For complete AGMA Service Factors and Load Classifications, see Engineering Pages 344 and 345.

# 800 SERIES IN-LINE HELICAL RATINGS

Non-Flanged  
Input Speeds 1750 RPM, 1450 RPM & 1160 RPM

Service Factor 1.0

Catalog Number	Input Speed								
	1750 RPM			1450 RPM			1160 RPM		
	Approx. Output RPM	Output Torque (LB-IN)(Max.)	Input HP (Max.)	Approx. Output RPM	Output Torque (LB-IN)(Max.)	Input HP (Max.)	Approx. Output RPM	Output Torque (LB-IN) (Max.)	Input HP (Max.)
832B/BF1.5S	1170	288	5.80	970	293	4.82	773	293	3.85
842B/BF1.5S	1170	479	9.08	970	509	8.00	773	549	6.89
862B/BF1.5S	1170	830	16.20	970	884	14.30	773	950	12.30
872B/BF1.5S	1170	1094	21.20	970	1090	17.50	773	1090	14.00

# 800 SERIES IN-LINE HELICAL MOUNTING POSITIONS

## FOOT MOUNTED HORIZONTAL

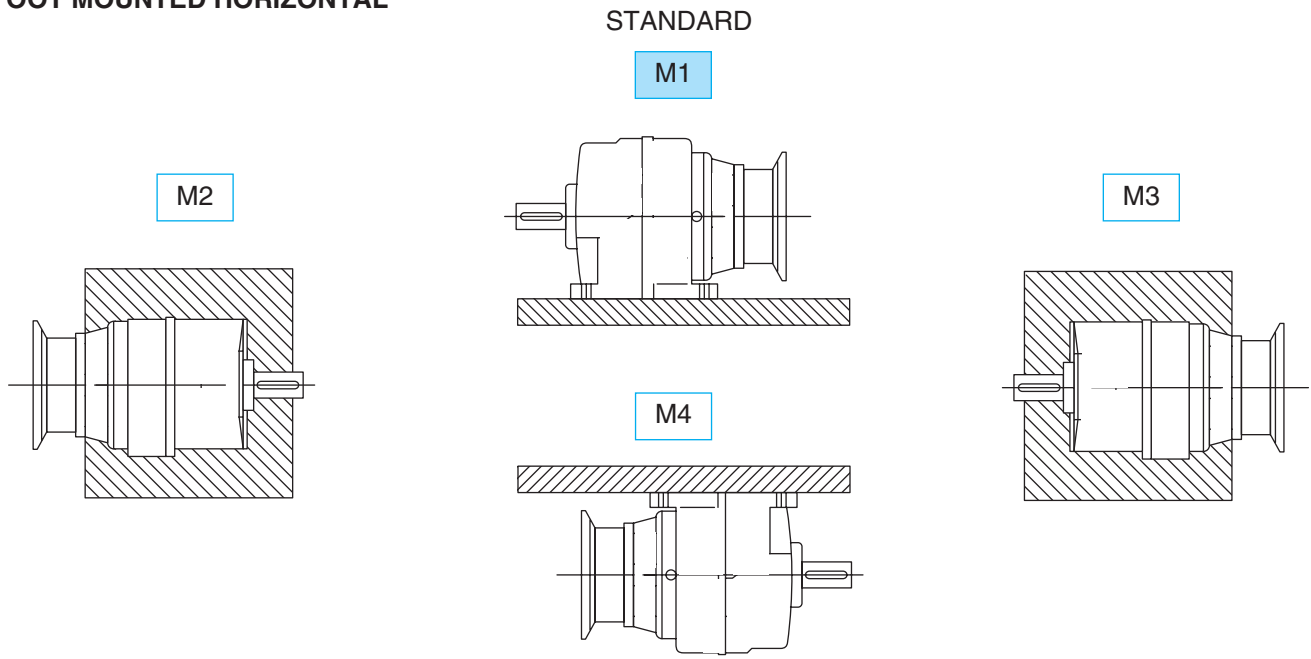

## FOOT MOUNTED VERTICAL



## OUTPUT FLANGE MOUNTED

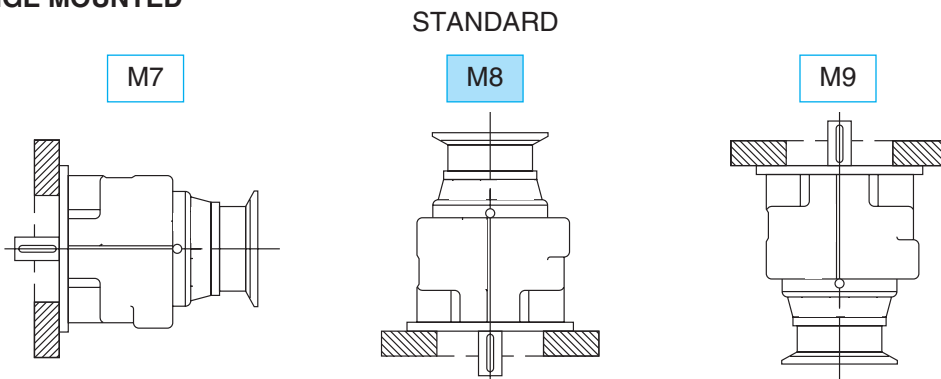

Positions M1 & M8 are standard and will be supplied with oil for this position unless otherwise specified.

**CAUTION - Mounting of gear drives in overhead positions may be hazardous. Use of external guides or supports is strongly recommended for overhead mounting.**

**Avoiding those positions where the high speed oil seal is immersed in oil will provide greater security against high speed input seal wear.**

Note: The above drawings will serve to represent both flanged and non-flanged styles

**BOSTON GEAR®**

800B Series 139

G

# 800 SERIES IN-LINE HELICAL GEAR DRIVES

## LUBRICANT AND QUANTITY

Synthetic SHC634 is recommended for the 800 Series gear drives and, at all times, the lubricant must remain free from contamination. Normal operating temperatures range between 150°F - 170°F. During the initial break-in of the gear drive, higher than normal operating temperatures may result.

All gear drives are supplied filled with SHC634 synthetic oil and with the quantity listed below for standard mounting position M1 or M8 or to mounting specified at time of order.

- Sizes 832/833B and 842/843B do not require a vent plug.
- Sizes 862/863B and 872/873B will require an oil change after 20,000 hours of operation. More frequent changes may be required when operating in high temperature ranges or unusually contaminated environments.
- Satisfactory performance may be obtained in some applications with non-synthetic oils and will require more frequent changes.

Recommended Lubricant	Ambient Temperature	ISO Viscosity Grade No.	Boston Gear Item Code	
			Quart	Gallon
Mobil SHC634	-30° to 225°F	320 / 460	51493	51494
Mobile D.T.E Oil Extra Heavy	50° to 125°F	710 / 790	N/A	N/A

## OIL CAPACITIES (QUARTS)

UNIT SIZE	MOUNTING POSITIONS								
	M1	M2	M3	M4	M5	M6	M7	M8	M9
	Foot Mounted						Output Flange Mounted		
832B	.63	.63	.84	.84	.84	1.1	.63	.84	1.1
833B	.84	.84	1.1	1.1	1.8	1.6	.84	1.8	1.6
842B	.63	.63	1.2	1.2	1.5	1.7	.63	1.5	1.7
843B	.95	.95	1.4	1.4	2.2	2.2	.95	2.4	2.2
862B	1.3	1.3	2.3	2.3	3.0	3.4	1.3	3.0	3.4
863B	1.9	1.9	2.7	2.7	5.0	5.0	1.9	5.0	5.0
872B	2.6	2.6	4.8	4.8	6.3	7.1	2.6	6.3	7.1
873B	3.0	3.8	5.9	5.9	9.5	9.5	3.0	10.8	9.5

Refer to mounting positions on page 139

# 800 SERIES IN-LINE HELICAL GEAR DRIVES

## OVERHUNG LOADS (LBS) & AXIAL THRUST (LBS) CAPACITIES ON OUTPUT SHAFT

OUTPUT RPM	832 / 833 OHL	842 / 843 OHL	862 / 863 OHL	872 / 873 OHL
1000	270	425	715	950
500	300	455	805	1065
350	340	465	830	1065
250	360	485	880	1065
200	385	505	900	1065
150	385	525	945	1090
100	385	620	1010	1275
50	385	770	1360	1720
25 & under	385	770	1600	2090

THRUST	390	635	1200	1580
--------	-----	-----	------	------

Overhung loads are calculated at the center of the shaft extension and with no thrust load. For combined loading consult factory.

## OVERHUNG LOADS (LBS) ON INPUT SHAFT AT 1750 RPM

SIZE	832	833	842	843	862	863	872	873
OHL	344	390	314	373	310	315	402	371

Overhung loads are calculated at the center of the shaft extension and with no thrust load.

## APPROXIMATE WEIGHTS (LBS)

NON-FLANGE		FLANGE				
SIZE	LBS	SIZE	NEMA MOUNTING			
			56C B5	140TC B7	180TC B9	210TC B11
832B	19	F832B	22	22	25	--
832BF	21	F832BF	24	24	27	--
842B	25	F842B	29	29	32	--
842BF	29	F842BF	33	33	36	--
862B	48	F862B	49	49	63	63
862BF	50	F862BF	51	51	66	66
872B	86	F872B	92	92	99	99
872BF	92	F872BF	99	99	105	105
833B	26	F833B	30	--	--	--
833BF	29	F833BF	32	--	--	--
843B	33	F843B	37	--	--	--
843BF	37	F843BF	41	--	--	--
863B	57	F863B	61	61	--	--
863BF	59	F863BF	63	63	--	--
873B	106	F873B	107	107	121	--
873BF	113	F873BF	114	114	128	--

FOR RATINGS AT OTHER INPUT SPEEDS, SEE TABLES ON PAGES 159-168.

ORDER BY CATALOG NUMBER OR ITEM CODE

FOR STANDARD MOUNTING POSITIONS

Approx. Output RPM	Ratio *	Non-Flanged				Flanged (Gearmotors)				
		Gear Capacity		Non-Flange O/P	Output Flange	Ratings			Non-Flange O/P	Output Flange
		Output Torque (LB-IN.)	Input HP	Catalog No. (Item Code)	Catalog No. (Item Code)	Motor HP	Output Torque (LB-IN.)	S.C. **	Catalog No. (Item Code)	Catalog No. (Item Code)
1170	1.5	288	5.80	832B-1.5S (12422)	832BF-1.5S (16962)	5	251	I	F832B-1.5S-B9 (20578)	F832BF-1.5S-B9 (22144)
						3	149	II		
						2	98	III	F832B-1.5S-B7 (20576)	F832BF-1.5S-B7 (22118)
		479	9.08	842B-1.5S (14756)	842BF-1.5S (17086)	5	248	II	F842B-1.5S-B9 (22716)	F842BF-1.5S-B9 (22988)
						3	146	III		
830	16.20	862B-1.5S (16222)	862BF-1.5S (18318)	10	500	II	F862B-1.5S-B11 (23556)	F862BF-1.5S-B11 (24596)		
				7.5	380	III				
		1094	21.20	872B-1.5S (16658)	872BF-1.5S (19386)	10	510	III	F872B-1.5S-B11 (25324)	F872BF-1.5S-B11 (26890)
922	1.9	325	4.77	832B-1.9S (12464)	832BF-1.9S (16964)	3	200	II	F832B-1.9S-B9 (20616)	F832BF-1.9S-B9 (22252)
						2	133	III	F832B-1.9S-B7 (20606)	F832BF-1.9S-B7 (22154)
		643	8.69	842B-1.9S (14758)	842BF-1.9S (17088)	5	343	II	F842B-1.9S-B9 (22718)	F842BF-1.9S-B9 (23004)
						3	209	III		
		1100	15.40	862B-1.9S (16224)	862BF-1.9S (18326)	10	710	II	F862B-1.9S-B11 (23558)	F862BF-1.9S-B11 (24600)
						7.5	535	III		
		1492	21.20	872B-1.9S (16686)	872BF-1.9S (19388)	10	695	III	F872B-1.9S-B11 (25506)	F872BF-1.9S-B11 (26892)
						7.5	521	III		
760	2.3	333	4.29	832B-2.3S (12466)	832BF-2.3S (16966)	3	234	I	F832B-2.3S-B9 (20944)	F832BF-2.3S-B9 (22272)
						2	156	III	F832B-2.3S-B7 (20768)	F832BF-2.3S-B7 (22256)
		695	8.52	842B-2.3S (14760)	842BF-2.3S (17090)	5	378	II	F842B-2.3S-B9 (22720)	F842BF-2.3S-B9 (23012)
						3	226	III		
		1217	15.00	862B-2.3S (16226)	862BF-2.3S (18548)	10	800	II	F862B-2.3S-B11 (23560)	F862BF-2.3S-B11 (24604)
7.5	600					III				
		1680	21.20	872B-2.3S (16700)	872BF-2.3S (19393)	10	780	III	F872B-2.3S-B11 (25518)	F872BF-2.3S-B11 (26894)
673 (CONT.)	2.6	350	3.98	832B-2.6S (12468)	832BF-2.6S (16968)	3	257	I	F832B-2.6S-B9 (20960)	F832BF-2.6S-B9 (22282)
						2	171	III	F832B-2.6S-B7 (20946)	F832BF-2.6S-B7 (22280)
		715	7.95	842B-2.6S (14762)	842BF-2.6S (17092)	5	416	II	F842B-2.6S-B9 (22722)	F842BF-2.6S-B9 (23016)
						3	250	III		

\* Gear Ratio is Approximate. For Actual Gear Ratio Reference Pages 159-168.

\*\*Service Class I (S.F. = 1.00) Service Class II (S.F. = 1.50) Service III (S.F. = 2.00)

Actual Output RPM = Input Speed ÷ Actual Ratio.

For Overhung Load Ratings refer to Page 141.

FOR RATINGS AT OTHER INPUT SPEEDS, SEE TABLES ON PAGES 159-168.

ORDER BY CATALOG NUMBER OR ITEM CODE

FOR STANDARD MOUNTING POSITIONS

Approx. Output RPM	Ratio *	Non-Flanged				Flanged (Gearmotors)				
		Gear Capacity		Non-Flange O/P	Output Flange	Ratings			Non-Flange O/P	Output Flange
		Output Torque (LB-IN.)	Input HP	Catalog No. (Item Code)	Catalog No. (Item Code)	Motor HP	Output Torque (LB-IN.)	S.C. **	Catalog No. (Item Code)	Catalog No. (Item Code)
673 (CONT.)	2.6	1320	14.50	862B-2.6S (16228)	862BF-2.6S (18552)	10	900	II	F862B-2.6S-B11 (23562)	F862BF-2.6S-B11 (24608)
		1800	21.20	872B-2.6S (16702)	872BF-2.6S (19400)	7.5	676	III		
605	2.9	533	5.18	832B-2.9S (12470)	832BF-2.9S (16970)	10	840	III	F872B-2.6S-B11 (25532)	F872BF-2.6S-B11 (26896)
		840	8.34	842B-2.9S (14770)	842BF-2.9S (17094)	5	508	I	F832B-2.9S-B9 (80812)	F832BF-2.9S-B9 (22284)
		1560	15.90	862B-2.9S (16230)	862BF-2.9S (18558)	3	305	III		
						10	972	II	F842B-2.9S-B9 (80825)	F842BF-2.9S-B9 (23020)
2135	21.20	872B-2.9S (16704)	872BF-2.9S (19401)	3	300	III				
530	3.3	370	3.24	832B-3.3S (12472)	832BF-3.3S (16972)	10	998	III	F862B-2.9S-B11 (80838)	F862BF-2.9S-B11 (24610)
						3	338	I	F872B-2.9S-B11 (80851)	F872BF-2.9S-B11 (26900)
						2	226	II	F832B-3.3S-B9 (21236)	F832BF-3.3S-B9 (22294)
		775	7.03	842B-3.3S (14802)	842BF-3.3S (17096)	1.5	169	III	F832B-3.3S-B7 (21214)	F832BF-3.3S-B7 (22288)
						5	510	I	F842B-3.3S-B9 (22728)	F842BF-3.3S-B9 (23026)
		1550	13.40	862B-3.3S (16232)	862BF-3.3S (18564)	3	306	III		
10	1145					I	F862B-3.3S-B11 (23608)	F862BF-3.3S-B11 (24614)		
2398	21.20	872B-3.3S (16708)	872BF-3.3S (19435)	7.5	858	II				
5	572	III	F862B-3.3S-B9 (23574)	F862BF-3.3S-B9 (24612)						
500	3.5	376	3.11	832B-3.5S (12474)	832BF-3.5S (16974)	10	1120	III	F872B-3.3S-B11 (25708)	F872BF-3.3S-B11 (26902)
						3	358	I	F832B-3.5S-B9 (21302)	F832BF-3.5S-B9 (22314)
						2	241	II	F832B-3.5S-B7 (21286)	F832BF-3.5S-B7 (22298)
		858	6.46	842B-3.5S (14806)	842BF-3.5S (17098)	1.5	180	III		
						5	600	I	F842B-3.5S-B9 (22730)	F842BF-3.5S-B9 (23038)
		1665	12.70	862B-3.5S (16234)	862BF-3.5S (18570)	3	358	III		
10	1298					I	F862B-3.5S-B11 (23692)	F862BF-3.5S-B11 (24618)		
2704	21.00	872B-3.5S (16710)	872BF-3.5S (19436)	7.5	974	II				
5	680	III	F862B-3.5S-B9 (23612)	F862BF-3.5S-B9 (24616)						
10	1275	III	F872B-3.5S-B11 (25718)	F872BF-3.5S-B11 (26904)						

\* Gear Ratio is Approximate. For Actual Gear Ratio Reference Pages 159-168.  
 \*\*Service Class I (S.F. = 1.00) Service Class II (S.F. = 1.50) Service III (S.F. = 2.00)  
 Actual Output RPM = Input Speed ÷ Actual Ratio.  
 For Overhung Load Ratings refer to Page 141.



FOR RATINGS AT OTHER INPUT SPEEDS, SEE TABLES ON PAGES 159-168.

ORDER BY CATALOG NUMBER OR ITEM CODE

FOR STANDARD MOUNTING POSITIONS

Approx. Output RPM	Ratio *	Non-Flanged				Flanged (Gearmotors)				
		Gear Capacity		Non-Flange O/P	Output Flange	Ratings			Non-Flange O/P	Output Flange
		Output Torque (LB-IN.)	Input HP	Catalog No. (Item Code)	Catalog No. (Item Code)	Motor HP	Output Torque (LB-IN.)	S.C. **	Catalog No. (Item Code)	Catalog No. (Item Code)
448	3.9	552	3.97	832B-3.9S (12476)	832BF-3.9S (16976)	3	412	I	F832B-3.9S-B9 (21306)	F832BF-3.9S-B9 (22320)
						2	275	III	F832B-3.9S-B7 (21304)	F832BF-3.9S-B7 (22316)
		959	6.96	842B-3.9S (14816)	842BF-3.9S (17102)	5	700	I	F842B-3.9S-B9 (22736)	F842BF-3.9S-B9 (23056)
						3	420	III		
		1835	13.30	862B-3.9S (16236)	862BF-3.9S (18572)	10	1366	I	F862B-3.9S-B11 (23788)	F862BF-3.9S-B11 (24622)
						7.5	1024	II		
5	683	III	F862B-3.9S-B9 (23778)	F862BF-3.9S-B9 (24620)						
2902	21.20	872B-3.9S (16724)	872BF-3.9S (19449)	10	1355	III	F872B-3.9S-B11 (25720)	F872BF-3.9S-B11 (32430)		
400	4.4	572	3.54	832B-4.4S (12478)	832BF-4.4S (16978)	3	480	I	F832B-4.4S-B9 (21318)	F832BF-4.4S-B9 (22350)
						2	320	II	F832B-4.4S-B7 (21312)	F832BF-4.4S-B7 (22342)
						1.5	240	III		
		1000	6.59	842B-4.4S (14832)	842BF-4.4S (17104)	5	773	I	F842B-4.4S-B9 (22740)	F842BF-4.4S-B9 (23058)
						3	464	III		
		1933	12.50	862B-4.4S (16238)	862BF-4.4S (18578)	10	1531	I	F862B-4.4S-B11 (23814)	F862BF-4.4S-B11 (24630)
7.5	1148					II				
5	766	III	F862B-4.4S-B9 (23810)	F862BF-4.4S-B9 (24628)						
3265	21.20	872B-4.4S (16726)	872BF-4.4S (19450)	10	1524	III	F872B-4.4S-B11 (25730)	F872BF-4.4S-B11 (32434)		
340	5.1	592	3.31	832B-5.1S (12528)	832BF-5.1S (16980)	3	531	I	F832B-5.1S-B9 (80813)	F832BF-5.1S-B9 (22370)
						2	354	II	F832B-5.1S-B7 (21330)	F832BF-5.1S-B7 (22366)
						1.5	266	III		
		1065	5.96	842B-5.1S (14840)	842BF-5.1S (17106)	5	840	I	F842B-5.1S-B9 (80826)	F842BF-5.1S-B9 (23068)
						3	504	III		
		2042	11.60	862B-5.1S (16240)	862BF-5.1S (18582)	10	1742	I	F862B-5.1S-B11 (80839)	F862BF-5.1S-B11 (24636)
7.5	1306					II				
5	870	III	F862B-5.1S-B9 (23840)	F862BF-5.1S-B9 (24634)						
3698	21.20	872B-5.1S (16730)	872BF-5.1S (19458)	10	1726	III	F872B-5.1S-B11 (80852)	F872BF-5.1S-B11 (26942)		

\* Gear Ratio is Approximate. For Actual Gear Ratio Reference Pages 159-168.  
 \*\*Service Class I (S.F. = 1.00) Service Class II (S.F. = 1.50) Service III (S.F. = 2.00)  
 Actual Output RPM = Input Speed ÷ Actual Ratio.  
 For Overhung Load Ratings refer to Page 141.

FOR RATINGS AT OTHER INPUT SPEEDS, SEE TABLES ON PAGES 159-168.

ORDER BY CATALOG NUMBER OR ITEM CODE

FOR STANDARD MOUNTING POSITIONS

Approx. Output RPM	Ratio *	Non-Flanged				Flanged (Gearmotors)					
		Gear Capacity		Non-Flange O/P	Output Flange	Ratings			Non-Flange O/P	Output Flange	
		Output Torque (LB-IN.)	Input HP	Catalog No. (Item Code)	Catalog No. (Item Code)	Motor HP	Output Torque (LB-IN.)	S.C. **	Catalog No. (Item Code)	Catalog No. (Item Code)	
307	5.7	563	2.91	832B-5.7S (12530)	832BF-5.7S (16982)	2	383	I	F832B-5.7S-B7 (21342)	F832BF-5.7S-B7 (22406)	
						1.5	287	II			
						1	191	III	F832B-5.7S-B5 (21340)	F832BF-5.7S-B5 (22390)	
		1110	5.64	842B-5.7S (14858)	842BF-5.7S (17108)	5	925	I	F842B-5.7S-B9 (22750)	F842BF-5.7S-B9 (23072)	
						3	555	II			
						2	370	III	F842B-5.7S-B7 (22748)	F842BF-5.7S-B7 (23070)	
		2140	10.80	862B-5.7S (16242)	862BF-5.7S (18584)	10	1891	I	F862B-5.7S-B11 (24048)	F862BF-5.7S-B11 (24644)	
						7.5	1464	II			
						5	976	III	F862B-5.7S-B9 (23864)	F862BF-5.7S-B9 (24642)	
		4160	21.20	872B-5.7S (16732)	872BF-5.7S (19548)	10	1942	III	F872B-5.7S-B11 (26084)	F872BF-5.7S-B11 (26944)	
273	6.4	588	2.52	832B-6.4S (12558)	832BF-6.4S (16984)	2	462	I	F832B-6.4S-B7 (21348)	F832BF-6.4S-B7 (22426)	
						1.5	346	II			
						1	230	III	F832B-6.4S-B5 (21344)	F832BF-6.4S-B5 (22414)	
		1095	5.34	842B-6.4S (14870)	842BF-6.4S (17110)	5	1014	I	F842B-6.4S-B9 (22754)	F842BF-6.4S-B9 (23080)	
						3	608	II			
						2	406	III	F842B-6.4S-B7 (22752)	F842BF-6.4S-B7 (23076)	
		2248	10.20	862B-6.4S (16244)	862BF-6.4S (18586)	10	2182	I	F862B-6.4S-B11 (24070)	F862BF-6.4S-B11 (24648)	
						7.5	1636	II			
						5	1091	III	F862B-6.4S-B9 (24056)	F862BF-6.4S-B9 (24646)	
		4623	20.90	872B-6.4S (16736)	872BF-6.4S (19558)	10	2189	III	F872B-6.4S-B11 (26086)	F872BF-6.4S-B11 (26946)	
246	7.2	576	2.34	832B-7.2S (12560)	832BF-7.2S (16986)	2	488	I	F832B-7.2S-B7 (21354)	F832BF-7.2S-B7 (22452)	
						1.5	366	II			
						1	244	III	F832B-7.2S-B5 (21350)	F832BF-7.2S-B5 (22430)	
		1171	4.88	842B-7.2S (14874)	842BF-7.2S (17112)	5	1171	I	F842B-7.2S-B9 (22758)	F842BF-7.2S-B9 (23084)	
						3	713	II			
						2	475	III	F842B-7.2S-B7 (22756)	F842BF-7.2S-B7 (23082)	
		2380	9.49	862B-7.2S (16250)	862BF-7.2S (18588)	7.5	1855	I	F862B-7.2S-B11 (24376)	F862BF-7.2S-B11 (24654)	
						5	1237	III	F862B-7.2S-B9 (24084)	F862BF-7.2S-B9 (24652)	
		4859	19.30	872B-7.2S (16738)	872BF-7.2S (19561)	10	2492	III	F872B-7.2S-B11 (26090)	F872BF-7.2S-B11 (26948)	

\* Gear Ratio is Approximate. For Actual Gear Ratio Reference Pages 159-168.

\*\*Service Class I (S.F. = 1.00) Service Class II (S.F. = 1.50) Service III (S.F. = 2.00)

Actual Output RPM = Input Speed ÷ Actual Ratio.

For Overhung Load Ratings refer to Page 141.

FOR RATINGS AT OTHER INPUT SPEEDS, SEE TABLES ON PAGES 159-168.

ORDER BY CATALOG NUMBER OR ITEM CODE

FOR STANDARD MOUNTING POSITIONS

Approx. Output RPM	Ratio *	Non-Flanged				Flanged (Gearmotors)						
		Gear Capacity		Non-Flange O/P	Output Flange	Ratings			Non-Flange O/P	Output Flange		
		Output Torque (LB-IN.)	Input HP	Catalog No. (Item Code)	Catalog No. (Item Code)	Motor HP	Output Torque (LB-IN.)	S.C. **	Catalog No. (Item Code)	Catalog No. (Item Code)		
218	8	560	2.01	832B-8S (12566)	832BF-8S (16988)	2	560	I	F832B-8S-B7 (21360)	F832BF-8S-B7 (22464)		
						1.5	415	II				
						1	276	III	F832B-8S-B5 (21356)	F832BF-8S-B5 (22458)		
		1206	4.54	842B-8S (15306)	842BF-8S (17114)	3	797	I	F842B-8S-B9 (22762)	F842BF-8S-B9 (23090)		
						2	526	III	F842B-8S-B7 (22760)	F842BF-8S-B7 (23086)		
						7.5	2087	I	F862B-8S-B11 (24382)	F862BF-8S-B11 (24806)		
		2480	8.82	862B-8S (16252)	862BF-8S (18590)	5	1391	II	F862B-8S-B9 (24378)	F862BF-8S-B9 (24804)		
						3	835	III				
						10	2790	II	F872B-8S-B11 (26094)	F872BF-8S-B11 (26952)		
		5074	18.00	872B-8S (16746)	872BF-8S (19578)	7.5	2092	III				
						1.5	508	I	F832B-9S-B7 (21368)	F832BF-9S-B7 (22470)		
						1	338	II	F832B-9S-B5 (21362)	F832BF-9S-B5 (22468)		
194	9	636	1.86	832B-9S (12568)	832BF-9S (16990)	.75	253	III				
						3	924	I	F842B-9S-B9 (22768)	F842BF-9S-B9 (23148)		
						2	616	III	F842B-9S-B7 (22764)	F842BF-9S-B7 (23096)		
		1275	4.14	842B-9S (15314)	842BF-9S (17116)	7.5	2366	I	F862B-9S-B11 (24392)	F862BF-9S-B11 (24810)		
						5	1577	II	F862B-9S-B9 (24384)	F862BF-9S-B9 (24808)		
						3	946	III				
		2608	8.18	862B-9S (16254)	862BF-9S (18592)	10	3175	II	F872B-9S-B11 (26096)	F872BF-9S-B11 (32524)		
						7.5	2381	III				
						1.5	524	I	F832B-10S-B7 (80814)	F832BF-10S-B7 (22478)		
		175	10	576	1.63	832B-10S (12570)	832BF-10S (16992)	1	349	II	F832B-10S-B5 (21372)	F832BF-10S-B5 (22476)
								.75	262	III		
								3	1006	I	F842B-10S-B9 (80828)	F842BF-10S-B9 (23156)
1295	3.82			842B-10S (15322)	842BF-10S (17118)	2	670	II	F842B-10S-B7 (22770)	F842BF-10S-B7 (23154)		
						1.5	503	III				
						7.5	2548	I	F862B-10S-B11 (80840)	F862BF-10S-B11 (24836)		
2600	7.56			862B-10S (16256)	862BF-10S (18594)	5	1700	II	F862B-10S-B9 (24396)	F862BF-10S-B9 (24812)		
						3	1019	III				
						10	3278	II	F872B-10S-B11 (80853)	F872BF-10S-B11 (26960)		
5360	15.70			872B-10S (16752)	872BF-10S (19580)	7.5	2458	III				

\* Gear Ratio is Approximate. For Actual Gear Ratio Reference Pages 159-168.  
 \*\*Service Class I (S.F. = 1.00) Service Class II (S.F. = 1.50) Service III (S.F. = 2.00)  
 Actual Output RPM = Input Speed ÷ Actual Ratio.  
 For Overhung Load Ratings refer to Page 141.

FOR RATINGS AT OTHER INPUT SPEEDS, SEE TABLES ON PAGES 159-168.

ORDER BY CATALOG NUMBER OR ITEM CODE

FOR STANDARD MOUNTING POSITIONS

Approx. Output RPM	Ratio *	Non-Flanged				Flanged (Gearmotors)				
		Gear Capacity		Non-Flange O/P	Output Flange	Ratings			Non-Flange O/P	Output Flange
		Output Torque (LB-IN.)	Input HP	Catalog No. (Item Code)	Catalog No. (Item Code)	Motor HP	Output Torque (LB-IN.)	S.C. **	Catalog No. (Item Code)	Catalog No. (Item Code)
159	11	576	1.43	832B-11S (12572)	832BF-11S (16994)	1	400	I	F832B-11S-B5 (21384)	F832BF-11S-B5 (22482)
						.75	300	II		
		1330	3.45	842B-11S (15490)	842BF-11S (17120)	3	1144	I	F842B-11S-B9 (22778)	F842BF-11S-B9 (23178)
						2	827	II		
						1.5	572	III		
2680	6.70	862B-11S (16348)	862BF-11S (18600)	5	1975	I	F862B-11S-B9 (24404)	F862BF-11S-B9 (24848)		
				3	1186	III				
5291	13.70	872B-11S (16758)	872BF-11S (19614)	10	3822	I	F872B-11S-B11 (26136)	F872BF-11S-B11 (32582)		
				7.5	2866	II				
145	12	550	1.30	832B-12S (12786)	832BF-12S (16996)	1	418	I	F832B-12S-B5 (21386)	F832BF-12S-B5 (22490)
						.75	314	II		
		1419	3.23	842B-12S (15598)	842BF-12S (17122)	3	1304	I	F842B-12S-B9 (22788)	F842BF-12S-B9 (23186)
						2	870	II		
						1.5	652	III		
2840	6.49	862B-12S (16354)	862BF-12S (18608)	5	2167	I	F862B-12S-B9 (24418)	F862BF-12S-B9 (24850)		
				3	1300	III				
5439	12.50	872B-12S (16760)	872BF-12S (19626)	10	4177	I	F872B-12S-B11 (26162)	F872BF-12S-B11 (32616)		
				7.5	3132	II				
125	14	550	1.14	832B-14S (12802)	832BF-14S (17002)	1	478	I	F832B-14S-B5 (80815)	F832BF-14S-B5 (22494)
						.75	358	II		
		1443	2.89	842B-14S (15752)	842BF-14S (17124)	2	988	II	F842B-14S-B7 (80829)	F842BF-14S-B7 (23190)
						1.5	741	III		
						5	2519	I		
		2910	5.72	862B-14S (16390)	862BF-14S (18610)	3	1512	III	F862B-14S-B9 (80841)	F862BF-14S-B9 (24852)
10	4870					I				
5364	10.90	872B-14S (16778)	872BF-14S (19640)	10	4870	I	F872B-14S-B11 (80854)	F872BF-14S-B11 (32922)		
				7.5	3653	II				
						5	2435	III	F872B-14S-B9 (26164)	F872BF-14S-B9 (32896)

\* Gear Ratio is Approximate. For Actual Gear Ratio Reference Pages 159-168.

\*\*Service Class I (S.F. = 1.00) Service Class II (S.F. = 1.50) Service III (S.F. = 2.00)

Actual Output RPM = Input Speed ÷ Actual Ratio.

For Overhung Load Ratings refer to Page 141.

FOR RATINGS AT OTHER INPUT SPEEDS, SEE TABLES ON PAGES 159-168.

ORDER BY CATALOG NUMBER OR ITEM CODE

FOR STANDARD MOUNTING POSITIONS

Approx. Output RPM	Ratio *	Non-Flanged				Flanged (Gearmotors)				
		Gear Capacity		Non-Flange O/P	Output Flange	Ratings			Non-Flange O/P	Output Flange
		Output Torque (LB-IN.)	Input HP	Catalog No. (Item Code)	Catalog No. (Item Code)	Motor HP	Output Torque (LB-IN.)	S.C. **	Catalog No. (Item Code)	Catalog No. (Item Code)
109	16	576	1.06	832B-16S (12882)	832BF-16S (17006)	1	539	I	F832B-16S-B5 (21392)	F832BF-16S-B5 (22498)
						.75	404	II		
		1380	2.49	842B-16S (15916)	842BF-16S (17126)	2	1097	II	F842B-16S-B7 (22796)	F842BF-16S-B7 (23196)
						1.5	823	II		
						1	548	III		
		2900	5.12	862B-16S (16396)	862BF-16S (18612)	5	2792	I	F862B-16S-B9 (24470)	F862BF-16S-B9 (24860)
						3	1675	II		
						2	1117	III		
		5245	9.60	872B-16S (16782)	872BF-16S (19652)	7.5	4055	I	F872B-16S-B11 (26244)	F872BF-16S-B11 (33532)
						5	2703	II		
3	1639					III				
97	18	590	0.91	832B-18S (13512)	832BF-18S (17008)	.75	483	I	F832B-18S-B5 (80816)	F832BF-18S-B5 (22500)
						.50	322	II		
		1420	2.35	842B-18S (15922)	842BF-18S (17128)	2	1192	I	F842B-18S-B7 (80830)	F842BF-18S-B7 (23212)
						1.5	894	II		
						1	596	III		
		2940	4.88	862B-18S (16398)	862BF-18S (18616)	3	1788	II	F862B-18S-B9 (80842)	F862BF-18S-B9 (24870)
						2	1192	III		
		5320	8.50	872B-18S (16784)	872BF-18S (19654)	7.5	4645	I	F872B-18S-B11 (80857)	F872BF-18S-B11 (33600)
						5	3096	II		
		87 (CONT.)	20	590	0.85	832B-20S (13548)	832BF-20S (17014)	.75	526	I
.50	350							II		
1442	2.01			842B-20S (15924)	842BF-20S (17130)	2	1420	I	F842B-20S-B7 (22818)	F842BF-20S-B7 (23218)
						1.5	1065	II		
						.75	533	III		

\* Gear Ratio is Approximate. For Actual Gear Ratio Reference Pages 159-168.  
 \*\*Service Class I (S.F. = 1.00) Service Class II (S.F. = 1.50) Service III (S.F. = 2.00)  
 Actual Output RPM = Input Speed ÷ Actual Ratio.  
 For Overhung Load Ratings refer to Page 141.

FOR RATINGS AT OTHER INPUT SPEEDS, SEE TABLES ON PAGES 159-168.  
 ORDER BY CATALOG NUMBER OR ITEM CODE  
 FOR STANDARD MOUNTING POSITIONS

Approx. Output RPM	Ratio *	Non-Flanged				Flanged (Gearmotors)				
		Gear Capacity		Non-Flange O/P	Output Flange	Ratings			Non-Flange O/P	Output Flange
		Output Torque (LB-IN.)	Input HP	Catalog No. (Item Code)	Catalog No. (Item Code)	Motor HP	Output Torque (LB-IN.)	S.C. **	Catalog No. (Item Code)	Catalog No. (Item Code)
87 (CONT.)	20	3014	4.19	862B-20S (16400)	862BF-20S (18618)	3	2137	I	F862B-20S-B9 (24478)	F862BF-20S-B9 (24874)
						2	1425	III	F862B-20S-B7 (24476)	F862BF-20S-B7 (24872)
		5319	7.64	872B-20S (16786)	872BF-20S (19655)	7.5	5319	I	F872B-20S-B11 (26254)	F872BF-20S-B11 (33680)
						5	3444	II	F872B-20S-B9 (26252)	F872BF-20S-B9 (33642)
79	22	574	0.72	832B-22S (13550)	832BF-22S (17016)	.75	574	I	F832B-22S-B5 (80817)	F832BF-22S-B5 (22518)
						.50	395	II		
						.33	260	III		
		1443	1.85	842B-22S (16014)	842BF-22S (17132)	1.5	1158	I	F842B-22S-B7 (80831)	F842BF-22S-B7 (23248)
						1	772	II	F842B-22S-B5 (22824)	F842BF-22S-B5 (23224)
		3030	3.95	862B-22S (16402)	862BF-22S (18620)	3	2281	I	F862B-22S-B9 (80843)	F862BF-22S-B9 (24886)
						2	1520	III	F862B-22S-B7 (24480)	F862BF-22S-B7 (24876)
		5398	6.77	872B-22S (16808)	872BF-22S (19662)	5	3946	I	F872B-22S-B9 (80858)	F872BF-22S-B9 (33682)
						3	2367	III		
		70	25	580	0.65	832B-25S (13552)	832BF-25S (17018)	.50	442	I
.33	294							III		
1312	1.64			842B-25S (16016)	842BF-25S (17134)	1.5	1187	I	F842B-25S-B7 (22838)	F842BF-25S-B7 (23264)
						1	791	II	F842B-25S-B5 (22836)	F842BF-25S-B5 (23262)
3070	3.49			862B-25S (16404)	862BF-25S (18714)	3	2618	I	F862B-25S-B9 (24486)	F862BF-25S-B9 (24898)
						2	1745	II	F862B-25S-B7 (24484)	F862BF-25S-B7 (24892)
5279	6.17			872B-25S (16824)	872BF-25S (19693)	1.5	1309	III		
		5	4236			I	F872B-25S-B9 (26258)	F872BF-25S-B9 (33696)		
62 (CONT.)	28	580	0.59	832B-28S (13554)	832BF-28S (17020)	.50	491	I	F832B-28S-B5 (80818)	F832BF-28S-B5 (22536)
						.33	327	II		
						.25	245	III		

\* Gear Ratio is Approximate. For Actual Gear Ratio Reference Pages 159-168.  
 \*\*Service Class I (S.F. = 1.00) Service Class II (S.F. = 1.50) Service III (S.F. = 2.00)  
 Actual Output RPM = Input Speed ÷ Actual Ratio.  
 For Overhung Load Ratings refer to Page 141.



FOR RATINGS AT OTHER INPUT SPEEDS, SEE TABLES ON PAGES 159-168.

ORDER BY CATALOG NUMBER OR ITEM CODE

FOR STANDARD MOUNTING POSITIONS

Approx. Output RPM	Ratio *	Non-Flanged				Flanged (Gearmotors)				
		Gear Capacity		Non-Flange O/P	Output Flange	Ratings			Non-Flange O/P	Output Flange
		Output Torque (LB-IN.)	Input HP	Catalog No. (Item Code)	Catalog No. (Item Code)	Motor HP	Output Torque (LB-IN.)	S.C. **	Catalog No. (Item Code)	Catalog No. (Item Code)
62 (CONT.)	28	1467	1.46	842B-28S (16018)	842BF-28S (17136)	1.5	1467	I	F842B-28S-B7 (22846)	F842BF-28S-B7 (23268)
						1	994	II	F842B-28S-B5 (80832)	F842BF-28S-B5 (23266)
		3070	3.19	862B-28S (16406)	862BF-28S (18716)	3	2867	I	F862B-28S-B9 (80844)	F862BF-28S-B9 (24916)
						2	1910	II	F862B-28S-B7 (24488)	F862BF-28S-B7 (24914)
		5287	5.64	872B-28S (16826)	872BF-28S (19720)	5	4639	I	F872B-28S-B9 (80859)	F872BF-28S-B9 (33720)
						3	2783	II	F872B-28S-B7 (26264)	F872BF-28S-B7 (33702)
				2	1855	III				
54	32	555	0.52	832B-32S (13556)	832BF-32S (17022)	.50	528	I	F832B-32S-B5 (21648)	F832BF-32S-B5 (22608)
						.33	237	II		
						.25	264	III		
		1338	1.29	842B-32S (16024)	842BF-32S (17468)	1	1026	I	F842B-32S-B5 (22848)	F842BF-32S-B5 (23270)
						.75	770	II		
						.50	513	III		
3120	2.79	862B-32S (16410)	862BF-32S (18734)	2	2225	II	F862B-32S-B7 (24500)	F862BF-32S-B7 (24936)		
				1.5	1669	II				
				1	1159	III	F862B-32S-B5 (24498)	F862BF-32S-B5 (24926)		
5342	4.90	872B-32S (16828)	872BF-32S (19803)	5	5342	I	F872B-32S-B9 (26306)	F872BF-32S-B9 (33732)		
				3	3236	II	F872B-32S-B7 (26268)	F872BF-32S-B7 (27090)		
				2	2158	III				
48 (CONT.)	36	557	0.47	832B-36S (13558)	832BF-36S (17024)	.50	557	I	F832B-36S-B5 (80819)	F832BF-36S-B5 (22618)
						.33	391	I		
						.25	294	II		
		562	0.47	833B-36S (13712)	833BF-36S (17044)	.50	562	I	F833B-36S-B5 (21698)	F833BF-36S-B5 (22684)
						.33	400	I		
						.25	299	II		
1457	1.15	842B-36S (16026)	842BF-36S (17474)	1	1254	I	F842B-36S-B5 (80833)	F842BF-36S-B5 (23272)		
				.75	940	II				
				.50	627	III				

\* Gear Ratio is Approximate. For Actual Gear Ratio Reference Pages 159-168.  
 \*\*Service Class I (S.F. = 1.00) Service Class II (S.F. = 1.50) Service III (S.F. = 2.00)  
 Actual Output RPM = Input Speed ÷ Actual Ratio.  
 For Overhung Load Ratings refer to Page 141.  
 ■ Indicates Triple Reduction

FOR RATINGS AT OTHER INPUT SPEEDS, SEE TABLES ON PAGES 159-168.

ORDER BY CATALOG NUMBER OR ITEM CODE

FOR STANDARD MOUNTING POSITIONS

Approx. Output RPM	Ratio *	Non-Flanged				Flanged (Gearmotors)				
		Gear Capacity		Non-Flange O/P	Output Flange	Ratings			Non-Flange O/P	Output Flange
		Output Torque (LB-IN.)	Input HP	Catalog No. (Item Code)	Catalog No. (Item Code)	Motor HP	Output Torque (LB-IN.)	S.C. **	Catalog No. (Item Code)	Catalog No. (Item Code)
48 (CONT.)	36	1390	1.17	843B-36S (16058)	843BF-36S (17492)	1	1190	I	F843B-36S-B5 (22910)	F843BF-36S-B5 (23294)
						.75	893	II		
						.50	595	III		
		3120	2.55	862B-36S (16414)	862BF-36S (18736)	2	2436	I	F862B-36S-B7 (80845)	F862BF-36S-B7 (24946)
						1.5	1827	II		
						1	1218	III		
		2978	2.51	863B-36S (16432)	863BF-36S (18954)	2	2372	I	F863B-36S-B7 (24534)	F863BF-36S-B7 (25002)
						1.5	1779	II		
						1	1186	III		
		5296	4.48	872B-36S (16852)	872BF-36S (19805)	5	5296	I	F872B-36S-B9 (26486)	F872BF-36S-B9 (33738)
						3	3546	II		
						2	2364	III		
5225	4.42	873B-36S (16912)	873BF-36S (19859)	5	5225	I	F873B-36S-B9 (30592)	F873BF-36S-B9 (27280)		
				3	3546	II				
				2	2364	III				
43 (CONT.)	40	466	0.36	832B-40S (13560)	832BF-40S (17026)	.33	431	I	F832B-40S-B5 (21654)	F832BF-40S-B5 (22638)
						.25	323	I		
						.16	216	III		
		560	0.41	833B-40S (13724)	833BF-40S (17046)	.33	456	I	F833B-40S-B5 (21704)	F833BF-40S-B5 (22686)
						.25	342	II		
						.16	228	III		
		1375	1.00	842B-40S (16030)	842BF-40S (17476)	1	1254	I	F842B-40S-B5 (22880)	F842BF-40S-B5 (23274)
						.75	940	II		
						.50	627	III		
		1390	1.02	843B-40S (16066)	843BF-40S (17496)	1	1360	I	F843B-40S-B5 (22912)	F843BF-40S-B5 (23300)
						.75	1020	I		
						.50	680	III		
2992	2.18	862B-40S (16416)	862BF-40S (18738)	2	2678	I	F862B-40S-B7 (24508)	F862BF-40S-B7 (24968)		
				1.5	2008	II				
				1	1339	III				
2978	2.21	863B-40S (16536)	863BF-40S (18974)	2	2695	I	F863B-40S-B7 (24540)	F863BF-40S-B7 (25008)		
				1.5	2022	II				
				1	1348	III				

\* Gear Ratio is Approximate. For Actual Gear Ratio Reference Pages 159-168.  
 \*\*Service Class I (S.F. = 1.00) Service Class II (S.F. = 1.50) Service III (S.F. = 2.00)  
 Actual Output RPM = Input Speed ÷ Actual Ratio.  
 For Overhung Load Ratings refer to Page 141.  
 Indicates Triple Reduction



FOR RATINGS AT OTHER INPUT SPEEDS, SEE TABLES ON PAGES 159-168.

ORDER BY CATALOG NUMBER OR ITEM CODE

FOR STANDARD MOUNTING POSITIONS

Approx. Output RPM	Ratio *	Non-Flanged				Flanged (Gearmotors)						
		Gear Capacity		Non-Flange O/P	Output Flange	Ratings			Non-Flange O/P	Output Flange		
		Output Torque (LB-IN.)	Input HP	Catalog No. (Item Code)	Catalog No. (Item Code)	Motor HP	Output Torque (LB-IN.)	S.C. **	Catalog No. (Item Code)	Catalog No. (Item Code)		
43 (CONT.)	40	5050	3.83	872B-40S (16854)	872BF-40S (19807)	3	3955	I	F872B-40S-B7 (26488)	F872BF-40S-B7 (33758)		
		5225	3.80	873B-40S (16914)	873BF-40S (19897)	2	2636	III				
						3	4125	I	F873B-40S-B7 (30598)	F873BF-40S-B7 (27284)		
38	45	480	0.33	832B-45S (13562)	832BF-45S (17030)	.33	480	I	F832B-45S-B5 (80820)	F832BF-45S-B5 (22662)		
						.25	359	I				
						.16	239	III				
		544	0.38	833B-45S (13726)	833BF-45S (17048)	.33	478	I	F833B-45S-B5 (21706)	F833BF-45S-B5 (22688)		
						.25	358	I				
						.16	239	III				
		1410	0.90	842B-45S (16032)	842BF-45S (17480)	.75	1180	I	F842B-45S-B5 (80834)	F842BF-45S-B5 (23276)		
						.50	788	II				
						.33	525	III				
		1420	0.92	843B-45S (16082)	843BF-45S (17600)	.75	1158	I	F843B-45S-B5 (22916)	F843BF-45S-B5 (23306)		
						.50	772	II				
						.33	515	III				
				2950	2.01	862B-45S (16420)	862BF-45S (18740)	2	2932	I	F862B-45S-B7 (80846)	F862BF-45S-B7 (24982)
								1.5	2199	I		
								1	1466	III	F862B-45S-B5 (24510)	F862BF-45S-B5 (24976)
		3040	2.01	863B-45S (16542)	863BF-45S (18982)	2	3025	I	F863B-45S-B7 (24544)	F863BF-45S-B7 (25012)		
						1.5	2269	I				
						1	1512	III	F863B-45S-B5 (24542)	F863BF-45S-B5 (25010)		
		5167	3.54	872B-45S (16882)	872BF-45S (19808)	3	4334	I	F872B-45S-B9 (80860)	F872BF-45S-B9 (33796)		
						2	3010	II	F872B-45S-B7 (26490)	F872BF-45S-B7 (33764)		
						1.5	2167	III				
		5300	3.52	873B-45S (16916)	873BF-45S (19918)	3	4526	I	F873B-45S-B9 (26752)	F873BF-45S-B9 (27292)		
						2	3013	II	F873B-45S-B7 (26708)	F873BF-45S-B7 (27286)		
						1.5	2404	III				
35 (CONT.)	50	555	0.34	832B-50S (13692)	832BF-50S (17032)	.33	540	I	F832B-50S-B5 (80821)	F832BF-50S-B5 (22672)		
						.25	405	I				
						.16	270	III				

\* Gear Ratio is Approximate. For Actual Gear Ratio Reference Pages 159-168.  
 \*\*Service Class I (S.F. = 1.00) Service Class II (S.F. = 1.50) Service III (S.F. = 2.00)  
 Actual Output RPM = Input Speed ÷ Actual Ratio.  
 For Overhung Load Ratings refer to Page 141.  
 ■ Indicates Triple Reduction

FOR RATINGS AT OTHER INPUT SPEEDS, SEE TABLES ON PAGES 159-168.

ORDER BY CATALOG NUMBER OR ITEM CODE

FOR STANDARD MOUNTING POSITIONS

Approx. Output RPM	Ratio *	Non-Flanged				Flanged (Gearmotors)				
		Gear Capacity		Non-Flange O/P	Output Flange	Ratings			Non-Flange O/P	Output Flange
		Output Torque (LB-IN.)	Input HP	Catalog No. (Item Code)	Catalog No. (Item Code)	Motor HP	Output Torque (LB-IN.)	S.C. **	Catalog No. (Item Code)	Catalog No. (Item Code)
35 (CONT.)	50	540	0.33	833B-50S (13738)	833BF-50S (17050)	.33	540	I	F833B-50S-B5 (21712)	F833BF-50S-B5 (22690)
						.25	409	I		
						.16	273	III		
		1500	0.87	842B-50S (16036)	842BF-50S (17484)	.75	1280	I	F842B-50S-B5 (80835)	F842BF-50S-B5 (23278)
						.50	854	II		
		1429	0.81	843B-50S (16110)	843BF-50S (17608)	.75	1323	I	F843B-50S-B5 (22918)	F843BF-50S-B5 (23336)
						.50	882	II		
		3150	1.86	862B-50S (16424)	862BF-50S (18742)	1.5	2514	I	F862B-50S-B7 (80847)	F862BF-50S-B7 (24986)
						1	1676	II		
		3040	1.77	863B-50S (16568)	863BF-50S (18984)	.75	1257	III	F862B-50S-B5 (24514)	F862BF-50S-B5 (24984)
						1.5	2578	I		
		5216	3.16	872B-50S (16886)	872BF-50S (19813)	1.5	2552	III	F863B-50S-B7 (24550)	F863BF-50S-B7 (25018)
1	1718					II				
5290	3.02	873B-50S (16918)	873BF-50S (19937)	3	4900	I	F863B-50S-B5 (24546)	F863BF-50S-B5 (25014)		
				2	3268	II				
5290	3.02	873B-50S (16918)	873BF-50S (19937)	1.5	2552	III	F872B-50S-B9 (80863)	F872BF-50S-B9 (33806)		
				2	3268	II				
5290	3.02	873B-50S (16918)	873BF-50S (19937)	3	5256	I	F872B-50S-B7 (26494)	F872BF-50S-B7 (33804)		
				2	3504	II				
5290	3.02	873B-50S (16918)	873BF-50S (19937)	1.5	2628	II	F873B-50S-B9 (30868)	F873BF-50S-B9 (27312)		
				2	3504	II				
31 (CONT.)	56	540	0.29	832B-56S (13694)	832BF-56S (17038)	.25	460	I	F832B-56S-B5 (80822)	F832BF-56S-B5 (22676)
						.16	308	II		
		554	0.30	833B-56S (13750)	833BF-56S (17052)	.25	462	I	F833B-56S-B5 (21714)	F833BF-56S-B5 (22692)
						.16	308	II		
		1392	0.71	842B-56S (16038)	842BF-56S (17486)	.5	970	I	F842B-56S-B5 (80836)	F842BF-56S-B5 (23280)
						.33	647	III		
		1396	0.76	843B-56S (16114)	843BF-56S (17612)	.75	1378	I	F843B-56S-B5 (22932)	F843BF-56S-B5 (23472)
						.50	918	II		
		2460	1.28	862B-56S (16426)	862BF-56S (18744)	.33	612	III	F862B-56S-B5 (80848)	F862BF-56S-B5 (24992)
						1	2018	I		
2460	1.28	862B-56S (16426)	862BF-56S (18744)	.75	1513	II	F862B-56S-B5 (80848)	F862BF-56S-B5 (24992)		
				.50	1000	III				

\* Gear Ratio is Approximate. For Actual Gear Ratio Reference Pages 159-168.  
 \*\*Service Class I (S.F. = 1.00) Service Class II (S.F. = 1.50) Service III (S.F. = 2.00)  
 Actual Output RPM = Input Speed ÷ Actual Ratio.  
 For Overhung Load Ratings refer to Page 141.  
 ■ Indicates Triple Reduction



FOR RATINGS AT OTHER INPUT SPEEDS, SEE TABLES ON PAGES 159-168.

ORDER BY CATALOG NUMBER OR ITEM CODE

FOR STANDARD MOUNTING POSITIONS

Approx. Output RPM	Ratio *	Non-Flanged				Flanged (Gearmotors)						
		Gear Capacity		Non-Flange O/P	Output Flange	Ratings			Non-Flange O/P	Output Flange		
		Output Torque (LB-IN.)	Input HP	Catalog No. (Item Code)	Catalog No. (Item Code)	Motor HP	Output Torque (LB-IN.)	S.C. **	Catalog No. (Item Code)	Catalog No. (Item Code)		
31 (CONT.)	56	2887	1.54	863B-56S (16570)	863BF-56S (18986)	1.5	2887	I	F863B-56S-B7 (24554)	F863BF-56S-B7 (25028)		
						1	1939	II	F863B-56S-B5 (24552)	F863BF-56S-B5 (25026)		
						.75	1459	III				
		4629	2.50	872B-56S (16898)	872BF-56S (19850)	2	3665	I	F872B-56S-B7 (80864)	F872BF-56S-B7 (33814)		
						1.5	2749	II				
		5227	2.69	873B-56S (16932)	873BF-56S (19957)	2	3886	I	F873B-56S-B7 (30872)	F873BF-56S-B7 (27342)		
						1.5	2915	II				
						1	1941	III	F873B-56S-B5 (30870)	F873BF-56S-B5 (27330)		
		27	63	500	0.25	832B-63S (13696)	832BF-63S (17040)	.25	500	I	F832B-63S-B5 (80823)	F832BF-63S-B5 (22680)
								.16	330	II		
.25	502							I	F833B-63S-B5 (21790)	F833BF-63S-B5 (22694)		
1475	0.70			842B-63S (16040)	842BF-63S (17488)	.50	1000	I	F842B-63S-B5 (80837)	F842BF-63S-B5 (23282)		
						.33	666	III				
1300	0.65			843B-63S (16142)	843BF-63S (17622)	.50	1044	I	F843B-63S-B5 (22936)	F843BF-63S-B5 (23474)		
						.33	696	III				
3098	1.52			862B-63S (16428)	862BF-63S (18950)	1.5	3027	I	F862B-63S-B7 (80849)	F862BF-63S-B7 (24996)		
						1	2018	II	F862B-63S-B5 (24520)	F862BF-63S-B5 (24994)		
						.75	1576	III				
2973	1.41			863B-63S (16576)	863BF-63S (18990)	1.5	2973	I	F863B-63S-B7 (24558)	F863BF-63S-B7 (25032)		
						1	2109	I	F863B-63S-B5 (24556)	F863BF-63S-B5 (25030)		
						.75	1582	II				
						.50	1054	III				
5300	2.64			872B-63S (16908)	872BF-63S (19855)	2	3993	I	F872B-63S-B7 (80867)	F872BF-63S-B7 (27198)		
						1.5	2995	II				
						1	2080	III	F872B-63S-B5 (30326)	F872BF-63S-B5 (27172)		
5226	2.52			873B-63S (16934)	873BF-63S (19962)	2	4149	I	F873B-63S-B7 (30876)	F873BF-63S-B7 (27602)		
		1.5	3112			II						
		1	2075			III	F873B-63S-B5 (30874)	F873BF-63S-B5 (27600)				

\* Gear Ratio is Approximate. For Actual Gear Ratio Reference Pages 159-168.  
 \*\*Service Class I (S.F. = 1.00) Service Class II (S.F. = 1.50) Service III (S.F. = 2.00)  
 Actual Output RPM = Input Speed ÷ Actual Ratio.  
 For Overhung Load Ratings refer to Page 141.  
 Indicates Triple Reduction

FOR RATINGS AT OTHER INPUT SPEEDS, SEE TABLES ON PAGES 159-168.

ORDER BY CATALOG NUMBER OR ITEM CODE

FOR STANDARD MOUNTING POSITIONS

Approx. Output RPM	Ratio *	Non-Flanged				Flanged (Gearmotors)				
		Gear Capacity		Non-Flange O/P	Output Flange	Ratings			Non-Flange O/P	Output Flange
		Output Torque (LB-IN.)	Input HP	Catalog No. (Item Code)	Catalog No. (Item Code)	Motor HP	Output Torque (LB-IN.)	S.C. **	Catalog No. (Item Code)	Catalog No. (Item Code)
24	71	500	0.22	832B-71S (13710)	832BF-71S (17042)	.25	500	I	F832B-71S-B5 (80824)	F832BF-71S-B5 (22682)
						.16	375	I		
		577	0.24	833B-71S (13776)	833BF-71S (17056)	.25	577	I	F833B-71S-B5 (21798)	F833BF-71S-B5 (22696)
						.16	400	I		
		1485	0.62	842B-71S (16042)	842BF-71S (17490)	.50	1186	I	F842B-71S-B5 (80865)	F842BF-71S-B5 (23284)
						.33	709	II		
		1427	0.60	843B-71S (16166)	843BF-71S (17630)	.50	1189	I	F843B-71S-B5 (22940)	F843BF-71S-B5 (23476)
						.25	592	III		
		2966	1.28	862B-71S (16430)	862BF-71S (18952)	1	2303	I	F862B-71S-B5 (80850)	F862BF-71S-B5 (24998)
						.75	1720	II		
		3040	1.23	863B-71S (16584)	863BF-71S (19172)	.50	1457	III	F863B-71S-B5 (24562)	F863BF-71S-B5 (25048)
						.75	1855	II		
5385	2.38	872B-71S (16910)	872BF-71S (19858)	.50	1236	III	F872B-71S-B7 (80868)	F872BF-71S-B7 (27236)		
				2	4479	I				
5298	2.14	873B-71S (16938)	873BF-71S (19965)	1.5	3359	II	F872B-71S-B5 (30506)	F872BF-71S-B5 (27210)		
				1	2239	III				
5298	2.14	873B-71S (16938)	873BF-71S (19965)	2	4952	I	F873B-71S-B7 (26792)	F873BF-71S-B7 (27606)		
				1.5	3714	II				
5298	2.14	873B-71S (16938)	873BF-71S (19965)	1	2476	III	F873B-71S-B5 (30904)	F873BF-71S-B5 (27604)		
				2	4952	I				
21	80	565	0.21	833B-80S (13778)	833BF-80S (17058)	.25	565	I	F833B-80S-B5 (21922)	F833BF-80S-B5 (22698)
						.16	448	I		
		1320	0.51	843B-80S (16170)	843BF-80S (17640)	.50	1294	I	F843B-80S-B5 (22942)	F843BF-80S-B5 (23478)
						.33	862	II		
		3038	1.13	863B-80S (16600)	863BF-80S (19184)	.25	647	III	F863B-80S-B5 (24564)	F863BF-80S-B5 (25050)
						1	2689	I		
		5315	2.01	873B-80S (16940)	873BF-80S (19973)	.75	2016	II	F873B-80S-B7 (30922)	F873BF-80S-B7 (27634)
						.50	1344	III		
5315	2.01	873B-80S (16940)	873BF-80S (19973)	2	5288	I	F873B-80S-B7 (30922)	F873BF-80S-B7 (27634)		
				1.5	3966	I				
5315	2.01	873B-80S (16940)	873BF-80S (19973)	1	2644	III	F873B-80S-B5 (30914)	F873BF-80S-B5 (27612)		
				2	5288	I				

\* Gear Ratio is Approximate. For Actual Gear Ratio Reference Pages 159-168.  
 \*\*Service Class I (S.F. = 1.00) Service Class II (S.F. = 1.50) Service III (S.F. = 2.00)  
 Actual Output RPM = Input Speed ÷ Actual Ratio.  
 For Overhung Load Ratings refer to Page 141.  
 ■ Indicates Triple Reduction



FOR RATINGS AT OTHER INPUT SPEEDS, SEE TABLES ON PAGES 159-168.

ORDER BY CATALOG NUMBER OR ITEM CODE

FOR STANDARD MOUNTING POSITIONS

Approx. Output RPM	Ratio *	Non-Flanged				Flanged (Gearmotors)				
		Gear Capacity		Non-Flange O/P	Output Flange	Ratings			Non-Flange O/P	Output Flange
		Output Torque (LB-IN.)	Input HP	Catalog No. (Item Code)	Catalog No. (Item Code)	Motor HP	Output Torque (LB-IN.)	S.C. **	Catalog No. (Item Code)	Catalog No. (Item Code)
19	90	575	0.19	833B-90S (14734)	833BF-90S (17060)	.16	504	I	F833B-90S-B5 (21934)	F833BF-90S-B5 (22700)
		1395	0.47	843B-90S (16174)	843BF-90S (17644)	.50	1398	I	F843B-90S-B5 (22958)	F843BF-90S-B5 (23480)
						.33	989	I		
						.25	741	II		
		2745	0.98	863B-90S (16602)	863BF-90S (19188)	.16	494	III	F863B-90S-B5 (24566)	F863BF-90S-B5 (25052)
						.75	2100	I		
						.50	1400	III		
		5252	1.73	873B-90S (16942)	873BF-90S (19976)	1.5	4554	I	F873B-90S-B7 (30934)	F873BF-90S-B7 (27638)
1	3035					II	F873B-90S-B5 (30924)	F873BF-90S-B5 (27636)		
.75	2277					III				
17	100	570	0.17	833B-100S (14736)	833BF-100S (17062)	.16	560	I	F833B-100S-B5 (21986)	F833BF-100S-B5 (22704)
		1400	0.42	843B-100S (16182)	843BF-100S (18160)	.33	1115	I	F843B-100S-B5 (22968)	F843BF-100S-B5 (23482)
						.25	836	II		
						.16	557	III		
		3095	0.88	863B-100S (16604)	863BF-100S (19217)	.75	2638	I	F863B-100S-B5 (24568)	F863BF-100S-B5 (25054)
						.50	1759	II	F873B-100S-B7 (32048)	F873BF-100S-B7 (27642)
						.33	1172	III		
		1.5	4986	I	F873B-100S-B5 (31764)	F873BF-100S-B5 (27640)				
5252	1.58	873B-100S (16944)	873BF-100S (19984)	.75	2498	III				
				1	3324	II				
15	112	543	0.15	833B-112S (14738)	833BF-112S (17064)	.16	543	I	F833B-112S-B5 (22102)	F833BF-112S-B5 (22708)
		1340	0.37	843B-112S (16188)	843BF-112S (18162)	.33	1282	I	F843B-112S-B5 (22972)	F843BF-112S-B5 (23484)
						.25	962	II		
						.16	641	III		
		2820	0.79	863B-112S (16606)	863BF-112S (19218)	.75	2678	I	F863B-112S-B5 (24570)	F863BF-112S-B5 (25056)
						.50	1786	II	F873B-112S-B5 (26840)	F873BF-112S-B5 (27650)
						.33	1190	III		
		1	3868	I						
5300	1.37	873B-112S (16946)	873BF-112S (19992)	.75	2900	II				
				.50	1934	III				

\* Gear Ratio is Approximate. For Actual Gear Ratio Reference Pages 159-168.  
 \*\*Service Class I (S.F. = 1.00) Service Class II (S.F. = 1.50) Service III (S.F. = 2.00)  
 Actual Output RPM = Input Speed ÷ Actual Ratio.  
 For Overhung Load Ratings refer to Page 141.  
 Indicates Triple Reduction

FOR RATINGS AT OTHER INPUT SPEEDS, SEE TABLES ON PAGES 159-168.

ORDER BY CATALOG NUMBER OR ITEM CODE

FOR STANDARD MOUNTING POSITIONS

Approx. Output RPM	Ratio *	Non-Flanged				Flanged (Gearmotors)					
		Gear Capacity		Non-Flange O/P	Output Flange	Ratings			Non-Flange O/P	Output Flange	
		Output Torque (LB-IN.)	Input HP	Catalog No. (Item Code)	Catalog No. (Item Code)	Motor HP	Output Torque (LB-IN.)	S.C. **	Catalog No. (Item Code)	Catalog No. (Item Code)	
14	125	523	0.13	833B-125S (14740)	833BF-125S (17066)	.16	523	I	F833B-125S-B5 (22106)	F833BF-125S-B5 (22710)	
		1430	0.33	843B-125S (16190)	843BF-125S (18164)	.33	1430	I	F843B-125S-B5 (22974)	F843BF-125S-B5 (23486)	
		3000	0.70	863B-125S (16608)	863BF-125S (19219)	.25 .16	1083 722	I III			
		5337	1.26	873B-125S (16948)	873BF-125S (20062)	.50 .33	2150 1433	I III	F863B-125S-B5 (24572)	F863BF-125S-B5 (25058)	
12	140	487	0.11	833B-140S (14742)	833BF-140S (17068)	.16	487	I	F833B-140S-B5 (22110)	F833BF-140S-B5 (22712)	
		1360	0.29	843B-140S (16192)	843BF-140S (18166)	.25	1175	I	F843B-140S-B5 (22976)	F843BF-140S-B5 (23490)	
		2916	0.65	863B-140S (16610)	863BF-140S (19230)	.16 .50	783 2443	II I	F863B-140S-B5 (24574)	F863BF-140S-B5 (25064)	
		5247	1.11	873B-140S (16950)	873BF-140S (20238)	.33 1	1495 4727	III I	F873B-140S-B5 (32060)	F873BF-140S-B5 (27800)	
10	160	490	0.10	833B-160S (14744)	833BF-160S (17070)	--	--	--	—	—	
		1410	0.27	843B-160S (16194)	843BF-160S (18192)	.25	1325	I	F843B-160S-B5 (22978)	F843BF-160S-B5 (23494)	
		3130	0.58	863B-160S (16612)	863BF-160S (19231)	.16 .50	883 2700	II I	F863B-160S-B5 (24576)	F863BF-160S-B5 (25066)	
		5280	1.02	873B-160S (16952)	873BF-160S (20258)	.33 .25	1800 1350	II III			
9.7 (CONT.)	180	555	0.10	833B-180S (14746)	833BF-180S (17074)	--	--	--	—	—	
		1436	0.24	843B-180S (16196)	843BF-180S (18194)	.25	1436	I	F843B-180S-B5 (22980)	F843BF-180S-B5 (23542)	
		3146	0.53	863B-180S (16630)	863BF-180S (19240)	.16 .50	997 2975	I I	F863B-180S-B5 (24578)	F863BF-180S-B5 (25068)	
						.33	1980	II			

\* Gear Ratio is Approximate. For Actual Gear Ratio Reference Pages 159-168.  
 \*\*Service Class I (S.F. = 1.00) Service Class II (S.F. = 1.50) Service III (S.F. = 2.00)  
 Actual Output RPM = Input Speed ÷ Actual Ratio.  
 For Overhung Load Ratings refer to Page 141.  
 Indicates Triple Reduction



FOR RATINGS AT OTHER INPUT SPEEDS, SEE TABLES ON PAGES 159-168.

ORDER BY CATALOG NUMBER OR ITEM CODE

FOR STANDARD MOUNTING POSITIONS

Approx. Output RPM	Ratio *	Non-Flanged				Flanged (Gearmotors)				
		Gear Capacity		Non-Flange O/P	Output Flange	Ratings			Non-Flange O/P	Output Flange
		Output Torque (LB-IN.)	Input HP	Catalog No. (Item Code)	Catalog No. (Item Code)	Motor HP	Output Torque (LB-IN.)	S.C. **	Catalog No. (Item Code)	Catalog No. (Item Code)
9.7 (CONT.)	180	5362	0.92	873B-180S (16954)	873BF-180S (20290)	.75	4371	I	F873B-180S-B5 (32320)	F873BF-180S-B5 (27900)
						.50	2914	II		
						.33	1942	III		
8.8	200	568	0.09	833B-200S (14748)	833BF-200S (17076)	--	--	--	--	--
		1428	0.21	843B-200S (16214)	843BF-200S (18196)	.25	1428	I	F843B-200S-B5 (22982)	F843BF-200S-B5 (23546)
		3173	0.47	863B-200S (16634)	863BF-200S (19326)	.33	2250	I	F863B-200S-B5 (24580)	F863BF-200S-B5 (25070)
						.25	1688	II		
				.16	1125	III				
		5432	0.82	873B-200S (16956)	873BF-200S (20398)	.75	4968	I	F873B-200S-B5 (26884)	F873BF-200S-B5 (27902)
						.50	3216	II		
				.33	2208	III				
7.8	225	544	0.08	833B-225S (14750)	833BF-225S (17078)	--	--	--	--	--
		1410	0.19	843B-225S (16216)	843BF-225S (18198)	.16	1219	I	F843B-225S-B5 (22984)	F843BF-225S-B5 (23550)
		3146	0.44	863B-225S (16636)	863BF-225S (19370)	.33	2383	I	F863B-225S-B5 (24588)	F863BF-225S-B5 (25072)
						.25	1788	II		
				.16	1192	III				
		5341	0.75	873B-225S (16958)	873BF-225S (20432)	.75	5341	I	F873B-225S-B5 (26886)	F873BF-225S-B5 (28253)
.50	3561					II				
		.33	2375	III						
7.0	250	540	0.07	833B-250S (14752)	833BF-250S (17080)	--	--	--	--	--
		1410	0.17	843B-250S (16220)	843BF-250S (18316)	.16	1385	I	F843B-250S-B5 (22986)	F843BF-250S-B5 (23554)
		3110	0.39	863B-250S (16654)	863BF-250S (19383)	.33	2709	I	F863B-250S-B5 (24594)	F863BF-250S-B5 (25314)
						.25	2032	II		
				.16	1355	III				
5423	0.67	873B-250S (16960)	873BF-250S (20478)	.50	4047	I	F873B-250S-B5 (26888)	F873BF-250S-B5 (28270)		
				.33	2698	III				

\* Gear Ratio is Approximate. For Actual Gear Ratio Reference Pages 159-168.  
 \*\*Service Class I (S.F. = 1.00) Service Class II (S.F. = 1.50) Service III (S.F. = 2.00)  
 Actual Output RPM = Input Speed ÷ Actual Ratio.  
 For Overhung Load Ratings refer to Page 141.  
 ■ Indicates Triple Reduction

# 800 SERIES RATIO AND CAPACITY SELECTION TABLES

Non-Flanged  
Input Speeds 1750 RPM, 1450 RPM & 1160 RPM

Service Factor 1.0\*

Catalog Number	Input Speed								
	1750 RPM			1450 RPM			1160 RPM		
	Approx. Output RPM	Output Torque (LB-IN)(Max.)	Input HP (Max.)	Approx. Output RPM	Output Torque (LB-IN)(Max.)	Input HP (Max.)	Approx. Output RPM	Output Torque (LB-IN) (Max.)	Input HP (Max.)
832B/BF1.5S	1170	288	5.80	970	293	4.82	773	293	3.85
842B/BF1.5S	1170	479	9.08	970	509	8.00	773	549	6.89
862B/BF1.5S	1170	830	16.20	970	884	14.30	773	950	12.30
872B/BF1.5S	1170	1094	21.20	970	1090	17.50	773	1090	14.00
832B/BF1.9S	922	325	4.77	763	325	3.95	610	325	3.16
842B/BF1.9S	922	643	8.69	763	685	7.66	610	738	6.60
862B/BF1.9S	922	1100	15.40	763	1189	13.60	610	1278	11.70
872B/BF1.9S	922	1492	21.20	763	1485	17.50	610	1484	14.00
832B/BF2.3S	760	333	4.29	630	339	3.56	504	339	2.84
842B/BF2.3S	760	695	8.52	630	739	7.51	504	788	6.40
862B/BF2.3S	760	1217	15.00	630	1292	13.20	504	1396	11.40
872B/BF2.3S	760	1680	21.20	630	1680	17.50	504	1680	14.00
832B/BF2.6S	673	350	3.98	560	350	3.30	446	350	2.64
842B/BF2.6S	673	715	7.95	560	762	7.01	446	777	5.72
862B/BF2.6S	673	1320	14.50	560	1408	12.80	446	1498	10.90
872B/BF2.6S	673	1800	21.20	560	1796	17.50	446	1796	14.00
832B/BF2.9S	605	533	5.18	500	544	4.38	400	559	3.60
842B/BF2.9S	605	840	8.34	500	872	7.35	400	939	6.33
862B/BF2.9S	605	1560	15.90	500	1660	14.00	400	1790	12.10
872B/BF2.9S	605	2135	21.20	500	2130	17.50	400	2130	14.00
832B/BF3.3S	530	370	3.24	440	370	2.69	350	370	2.15
842B/BF3.3S	530	775	7.03	440	775	5.83	350	775	4.66
862B/BF3.3S	530	1550	13.40	440	1648	11.80	350	1720	9.85
872B/BF3.3S	530	2398	21.20	440	2390	17.50	350	2390	14.00
832B/BF3.5S	500	376	3.11	414	376	2.57	331	376	2.06
842B/BF3.5S	500	858	6.46	414	832	5.35	331	832	4.28
862B/BF3.5S	500	1665	12.70	414	1751	11.10	331	1814	9.16
872B/BF3.5S	500	2704	21.00	414	2720	17.50	331	2720	14.00
832B/BF3.9S	448	552	3.97	372	563	3.36	297	576	2.75
842B/BF3.9S	448	959	6.96	372	1020	6.13	297	1100	5.28
862B/BF3.9S	448	1835	13.30	372	1950	11.70	297	2110	10.10
872B/BF3.9S	448	2902	21.20	372	2892	17.50	297	2892	14.00
832B/BF4.4S	400	572	3.54	330	585	3.00	264	588	2.41
842B/BF4.4S	400	1000	6.59	330	1066	5.81	264	1146	5.00
862B/BF4.4S	400	1933	12.50	330	2050	11.00	264	2215	9.49
872B/BF4.4S	400	3265	21.20	330	3254	17.50	264	3254	14.00
832B/BF5.1S	340	592	3.31	285	592	2.74	227	592	2.19
842B/BF5.1S	340	1065	5.96	285	1135	5.26	227	1232	4.53
862B/BF5.1S	340	2042	11.60	285	2167	10.20	227	2330	8.78
872B/BF5.1S	340	3698	21.20	285	3685	17.50	227	3685	14.00

\* For applications requiring a service factor greater than 1.0, multiply the design torque or horsepower by the application factor, found on pages 344-345.  
Actual Output RPM = Input Speed ÷ Actual Ratio.  
For Overhung Load Ratings refer to Page 141.

# 800 SERIES RATIO AND CAPACITY SELECTION TABLES

Non-Flanged  
Input Speeds 690 RPM, & 100 RPM

Service Factor 1.0\*

Catalog Number	Input Speed						Approx. Wt. (LB)	Actual Gear Ratio
	690 RPM			100 RPM				
	Approx. Output RPM	Output Torque (LB-IN)(Max.)	Input HP (Max.)	Approx. Output RPM	Output Torque (LB-IN)(Max.)	Input HP (Max.)		
832B/BF1.5S	460	293	2.29	67	293	.33	21	1.440
842B/BF1.5S	460	580	4.34	67	580	.63	29	1.512
862B/BF1.5S	460	1054	8.11	67	1058	1.18	51	1.467
872B/BF1.5S	460	1090	8.30	67	1090	1.20	99	1.479
832B/BF1.9S	363	325	1.87	53	325	.27	21	1.945
842B/BF1.9S	363	767	4.08	53	767	.59	29	2.121
862B/BF1.9S	363	1384	7.53	53	1384	1.09	51	2.074
872B/BF1.9S	363	1500	8.32	53	1500	1.21	99	2.012
832B/BF2.3S	300	337	1.68	43	333	.24	21	2.263
842B/BF2.3S	300	787	3.80	43	787	.55	29	2.337
862B/BF2.3S	300	1494	7.26	43	1492	1.05	51	2.324
872B/BF2.3S	300	1680	8.30	43	1680	1.20	99	2.261
832B/BF2.6S	265	350	1.56	38	350	.23	21	2.506
842B/BF2.6S	265	775	3.39	38	775	.49	29	2.577
862B/BF2.6S	265	1495	6.47	38	1500	.94	51	2.609
872B/BF2.6S	265	1792	8.31	38	1785	1.20	99	2.434
832B/BF2.9S	238	576	2.18	34	576	.32	21	2.945
842B/BF2.9S	238	1080	4.33	34	1080	.63	29	2.814
862B/BF2.9S	238	2018	8.10	34	2018	1.17	51	2.813
872B/BF2.9S	238	2140	8.30	34	2140	1.20	99	2.888
832B/BF3.3S	210	367	1.27	30	367	.18	21	3.268
842B/BF3.3S	210	772	2.76	30	772	.40	29	3.158
862B/BF3.3S	210	1788	6.09	30	1788	.88	51	3.313
872B/BF3.3S	210	2391	8.33	30	2391	1.21	99	3.240
832B/BF3.5S	197	376	1.22	28	376	.18	21	3.455
842B/BF3.5S	197	830	2.54	28	830	.37	29	3.692
862B/BF3.5S	197	1911	5.74	28	1911	.83	51	3.758
872B/BF3.5S	197	2391	7.32	28	2390	1.06	99	3.687
832B/BF3.9S	177	576	1.62	26	576	.23	21	3.978
842B/BF3.9S	177	1277	3.65	26	1277	.53	29	3.948
862B/BF3.9S	177	2540	7.18	26	2540	1.04	51	3.952
872B/BF3.9S	177	2880	8.29	26	2880	1.20	99	3.920
832B/BF4.4S	157	582	1.42	23	582	.21	21	4.630
842B/BF4.4S	157	1187	3.08	23	1187	.45	29	4.351
862B/BF4.4S	157	2374	6.05	23	2374	.88	51	4.429
872B/BF4.4S	157	3243	8.30	23	3243	1.20	99	4.410
832B/BF5.1S	135	585	1.29	20	585	.19	21	5.126
842B/BF5.1S	135	1288	2.84	20	1288	.41	29	5.119
862B/BF5.1S	135	2570	5.70	20	2570	.83	51	5.040
872B/BF5.1S	135	3660	8.27	20	3660	1.20	99	4.995

\* For applications requiring a service factor greater than 1.0, multiply the design torque or horsepower by the application factor, found on pages 344-345.  
Actual Output RPM = Input Speed ÷ Actual Ratio.  
For Overhung Load Ratings refer to Page 141.

# 800 SERIES RATIO AND CAPACITY SELECTION TABLES

Non-Flanged  
Input Speeds 1750 RPM, 1450 RPM & 1160 RPM

Service Factor 1.0\*

Catalog Number	Input Speed								
	1750 RPM			1450 RPM			1160 RPM		
	Approx. Output RPM	Output Torque (LB-IN)(Max.)	Input HP (Max.)	Approx. Output RPM	Output Torque (LB-IN)(Max.)	Input HP (Max.)	Approx. Output RPM	Output Torque (LB-IN) (Max.)	Input HP (Max.)
832B/BF5.7S	307	563	2.91	254	563	2.41	203	563	1.93
842B/BF5.7S	307	1110	5.64	254	1182	4.97	203	1272	4.28
862B/BF5.7S	307	2140	10.80	254	2280	9.56	203	2450	8.23
872B/BF5.7S	307	4160	21.20	254	4146	17.50	203	4146	14.00
832B/BF6.4S	273	588	2.52	226	588	2.08	181	588	1.67
842B/BF6.4S	273	1095	5.34	226	1138	4.60	181	1175	3.80
862B/BF6.4S	273	2248	10.20	226	2400	9.01	181	2501	7.52
872B/BF6.4S	273	4623	20.90	226	4674	17.50	181	4674	14.00
832B/BF7.2S	273	576	2.34	201	576	1.93	161	576	1.55
842B/BF7.2S	273	1171	4.88	201	1206	4.16	161	1246	3.44
862B/BF7.2S	273	2380	9.49	201	2500	8.26	161	2590	6.83
872B/BF7.2S	273	4859	19.30	201	5168	17.00	161	5282	13.90
832B/BF8S	218	560	2.01	181	560	1.66	145	560	1.33
842B/BF8S	218	1206	4.54	181	1254	3.91	145	1299	3.24
862B/BF8S	218	2480	8.82	181	2640	7.77	145	2760	6.49
872B/BF8S	218	5074	18.00	181	5343	15.70	145	5360	12.60
832B/BF9S	194	636	1.86	161	636	1.54	128	636	1.23
842B/BF9S	194	1275	4.14	161	1326	3.53	128	1414	2.92
862B/BF9S	194	2608	8.18	161	2737	7.11	128	2830	5.88
872B/BF9S	194	5358	16.70	161	5384	13.90	128	5375	11.10
832B/BF10S	175	576	1.63	145	576	1.35	116	576	1.08
842B/BF10S	175	1295	3.82	145	1330	3.26	116	1400	2.73
862B/BF10S	175	2600	7.56	145	2680	6.44	116	2780	5.36
872B/BF10S	175	5360	15.70	145	5238	13.10	116	5200	10.40
832B/BF11S	159	576	1.43	131	576	1.18	105	576	0.95
842B/BF11S	159	1330	3.45	131	1380	2.96	105	1420	2.43
862B/BF11S	159	2680	6.70	131	2760	5.72	105	2900	4.79
872B/BF11S	159	5291	13.70	131	5315	11.40	105	5304	9.10
832B/BF12S	145	550	1.30	120	550	1.08	96	550	0.86
842B/BF12S	145	1419	3.23	120	1488	2.72	96	1439	2.17
862B/BF12S	145	2840	6.49	120	2920	5.53	96	2990	4.52
872B/BF12S	145	5439	12.50	120	5300	10.40	96	5300	8.31
832B/BF14S	125	550	1.14	103	554	0.95	82	554	0.76
842B/BF14S	125	1443	2.89	103	1440	2.39	82	1440	1.91
862B/BF14S	125	2910	5.72	103	2970	4.83	82	3030	3.95
872B/BF14S	125	5364	10.90	103	5378	9.05	82	5378	7.24
832B/BF16S	109	576	1.06	90	576	0.88	72	576	0.70
842B/BF16S	109	1380	2.49	90	1380	2.06	72	1380	1.65
862B/BF16S	109	2900	5.12	90	3010	4.42	72	3070	3.60
872B/BF16S	109	5245	9.60	90	5250	7.96	72	5250	6.37

\* For applications requiring a service factor greater than 1.0, multiply the design torque or horsepower by the application factor, found on pages 344-345.  
Actual Output RPM = Input Speed ÷ Actual Ratio.  
For Overhung Load Ratings refer to Page 141



# 800 SERIES RATIO AND CAPACITY SELECTION TABLES

Non-Flanged  
Input Speeds 690 RPM, & 100 RPM

Service Factor 1.0\*

Catalog Number	Input Speed						Approx. Wt. (LB)	Actual Gear Ratio
	690 RPM			100 RPM				
	Approx. Output RPM	Output Torque (LB-IN)(Max.)	Input HP (Max.)	Approx. Output RPM	Output Torque (LB-IN)(Max.)	Input HP (Max.)		
832B/BF5.7S	121	555	1.13	18	555	.16	21	5.540
842B/BF5.7S	121	1320	2.64	18	1320	.38	29	5.641
862B/BF5.7S	121	2622	5.24	18	2622	.76	51	5.649
872B/BF5.7S	121	4112	8.26	18	4112	1.20	99	5.620
832B/BF6.4S	108	588	0.98	16	588	.14	21	6.685
842B/BF6.4S	108	1222	2.35	16	1222	.34	29	5.970
862B/BF6.4S	108	2674	4.78	16	2674	.69	51	6.313
872B/BF6.4S	108	4653	8.29	16	4653	1.20	99	6.335
832B/BF7.2S	96	576	0.91	14	576	.13	21	7.067
842B/BF7.2S	96	1315	2.16	14	1315	.31	29	6.874
862B/BF7.2S	96	2772	4.37	14	2722	.63	51	7.160
872B/BF7.2S	96	5276	8.26	14	5276	1.20	99	7.210
832B/BF8S	86	560	0.78	12	560	.11	21	8.000
842B/BF8S	86	1328	1.97	12	1328	.29	29	7.610
862B/BF8S	86	2867	4.02	12	2867	.58	51	8.051
872B/BF8S	86	5322	7.44	12	5322	1.08	99	8.073
832B/BF9S	77	633	0.73	11	633	.11	21	9.792
842B/BF9S	77	1366	1.73	11	1366	.25	29	8.913
862B/BF9S	77	2937	3.63	11	2937	.53	51	9.131
872B/BF9S	77	5324	6.54	11	5324	.95	99	9.188
832B/BF10S	69	576	0.64	10	576	.09	21	10.112
842B/BF10S	69	1402	1.63	10	1402	.24	29	9.706
862B/BF10S	69	2935	3.37	10	2935	.49	51	9.832
872B/BF10S	69	5194	6.18	10	5194	.90	99	9.485
832B/BF11S	63	576	0.56	9.1	576	.08	21	11.566
842B/BF11S	63	1420	1.44	9.1	1420	.21	29	11.025
862B/BF11S	63	2900	3.00	9.1	2900	.43	51	11.434
872B/BF11S	63	5272	5.38	9.1	5272	.78	99	11.060
832B/BF12S	57	550	0.51	8.3	550	.07	21	12.101
842B/BF12S	57	1416	1.27	8.3	1416	.18	29	12.584
862B/BF12S	57	3032	2.73	8.3	3032	.40	51	12.537
872B/BF12S	57	5247	4.90	8.3	5247	.71	99	12.087
832B/BF14S	49	539	0.44	7.1	539	.06	21	13.829
842B/BF14S	49	1418	1.12	7.1	1418	.16	29	14.295
862B/BF14S	49	3087	2.39	7.1	3087	.35	51	14.580
872B/BF14S	49	5320	4.26	7.1	5320	.62	99	14.094
832B/BF16S	43	576	0.41	6.2	576	.06	21	15.599
842B/BF16S	43	1363	0.97	6.2	1363	.14	29	15.866
862B/BF16S	43	3035	2.12	6.2	3035	.31	51	16.159
872B/BF16S	43	5212	3.76	6.2	5212	.55	99	15.645

\* For applications requiring a service factor greater than 1.0, multiply the design torque or horsepower by the application factor, found on pages 344-345.  
Actual Output RPM = Input Speed ÷ Actual Ratio.  
For Overhung Load Ratings refer to Page 141

# 800 SERIES RATIO AND CAPACITY SELECTION TABLES

Non-Flanged  
Input Speeds 1750 RPM, 1450 RPM & 1160 RPM

Service Factor 1.0\*

Catalog Number	Input Speed								
	1750 RPM			1450 RPM			1160 RPM		
	Approx. Output RPM	Output Torque (LB-IN)(Max.)	Input HP (Max.)	Approx. Output RPM	Output Torque (LB-IN)(Max.)	Input HP (Max.)	Approx. Output RPM	Output Torque (LB-IN) (Max.)	Input HP (Max.)
832B/BF18S	97	590	0.91	80	590	0.75	64	590	0.60
842B/BF18S	97	1420	2.35	80	1420	1.95	64	1420	1.56
862B/BF18S	97	2940	4.88	80	3060	4.20	64	3060	3.37
872B/BF18S	97	5320	8.50	80	5320	7.05	64	5320	5.64
832B/BF20S	87	590	0.85	72	590	0.70	58	590	0.56
842B/BF20S	87	1442	2.01	72	1442	1.67	58	1442	1.33
862B/BF20S	87	3014	4.19	72	3014	3.54	58	3014	2.88
872B/BF20S	87	5319	7.64	72	5266	6.33	58	5266	5.06
832B/BF22S	79	574	0.72	65	590	0.60	52	590	0.48
842B/BF22S	79	1443	1.85	65	1443	1.53	52	1443	1.23
862B/BF22S	79	3030	3.95	65	3090	3.34	52	3120	2.70
872B/BF22S	79	5398	6.77	65	5398	5.61	52	5398	4.48
832B/BF25S	70	580	0.65	58	580	0.54	46	580	0.43
842B/BF25S	70	1312	1.64	58	1312	1.36	46	1312	1.09
862B/BF25S	70	3070	3.49	58	3070	2.89	46	3070	2.31
872B/BF25S	70	5279	6.17	58	5279	5.11	46	5279	4.09
832B/BF28S	62	580	0.59	51	580	0.49	41	580	0.39
842B/BF28S	62	1467	1.46	51	1467	1.21	41	1467	0.97
862B/BF28S	62	3070	3.19	51	3070	2.64	41	3070	2.11
872B/BF28S	62	5287	5.64	51	5287	4.67	41	5287	3.74
832B/BF32S	54	555	0.52	45	555	0.43	36	555	0.34
842B/BF32S	54	1338	1.29	45	1338	1.07	36	1338	0.85
862B/BF32S	54	3120	2.79	45	3120	2.31	36	3120	1.85
872B/BF32S	54	5342	4.90	45	5342	4.06	36	5342	3.25
832B/BF36S	48	557	0.47	40	557	0.39	32	557	0.31
842B/BF36S	48	1457	1.15	40	1457	0.95	32	1457	0.76
862B/BF36S	48	3120	2.55	40	3120	2.11	32	3120	1.69
872B/BF36S	48	5296	4.48	40	5296	3.71	32	5296	2.97
833B/BF36S	48	562	0.47	40	562	0.39	32	562	0.31
843B/BF36S	48	1390	1.17	40	1390	0.97	32	1390	0.77
863B/BF36S	48	2978	2.51	40	2977	2.08	32	2977	1.66
873B/BF36S	48	5225	4.42	40	5225	3.66	32	5225	2.93
832B/BF40S	43	466	0.36	36	484	0.31	29	484	0.25
842B/BF40S	43	1375	1.00	36	1254	0.85	29	1254	0.69
862B/BF40S	43	2992	2.18	36	2930	1.84	29	2930	1.51
872B/BF40S	43	5050	3.83	36	5050	3.24	29	5050	2.63
833B/BF40S	43	560	0.41	36	562	0.34	29	562	0.27
843B/BF40S	43	1390	1.02	36	1390	0.85	29	1390	0.68
863B/BF40S	43	2978	2.21	36	2978	1.83	29	2978	1.46
873B/BF40S	43	5225	3.80	36	5225	3.15	29	5225	2.52

\* For applications requiring a service factor greater than 1.0, multiply the design torque or horsepower by the application factor, found on pages 344-345.

Actual Output RPM = Input Speed ÷ Actual Ratio.

For Overhung Load Ratings refer to Page 141.

Indicates Triple Reduction

# 800 SERIES RATIO AND CAPACITY SELECTION TABLES

Non-Flanged  
Input Speeds 690 RPM, & 100 RPM

Service Factor 1.0\*

Catalog Number	Input Speed						Approx. Wt. (LB)	Actual Gear Ratio
	690 RPM			100 RPM				
	Approx. Output RPM	Output Torque (LB-IN)(Max.)	Input HP (Max.)	Approx. Output RPM	Output Torque (LB-IN)(Max.)	Input HP (Max.)		
832B/BF18S	38	590	.35	5.5	590	.05	21	18.667
842B/BF18S	38	1420	.92	5.5	1420	.13	29	17.252
862B/BF18S	38	3060	1.99	5.5	3060	.29	51	17.253
872B/BF18S	38	5320	3.33	5.5	5320	.48	99	17.920
832B/BF20S	34	590	.33	5.0	590	.05	21	20.308
842B/BF20S	34	1442	.78	5.0	1442	.11	29	20.548
862B/BF20S	34	3014	1.69	5.0	3014	.25	51	20.606
872B/BF20S	34	5266	2.98	5.0	5266	.43	99	19.936
832B/BF22S	31	590	.28	4.5	590	.04	21	22.848
842B/BF22S	31	1425	.72	4.5	1425	.10	29	22.343
862B/BF22S	31	3120	1.58	4.5	3120	.23	51	22.001
872B/BF22S	31	5398	2.63	4.5	5398	.38	99	22.835
832B/BF25S	28	580	.25	4.0	580	.04	21	25.560
842B/BF25S	28	1312	.64	4.0	1312	.09	29	22.908
862B/BF25S	28	3070	1.36	4.0	3070	.20	51	25.246
872B/BF25S	28	5279	2.41	4.0	5279	.35	99	24.500
832B/BF28S	25	580	.23	3.6	580	.03	21	28.400
842B/BF28S	25	1467	.57	3.6	1467	.08	29	28.777
862B/BF28S	25	3070	1.24	3.6	3070	.18	51	27.643
872B/BF28S	25	5287	2.20	3.6	5287	.32	99	26.845
832B/BF32S	21	555	.20	3.1	555	.03	21	30.587
842B/BF32S	21	1315	.50	3.1	1338	.07	29	29.701
862B/BF32S	21	3120	1.08	3.1	3120	.16	51	32.193
872B/BF32S	21	5342	1.91	3.1	5344	.28	99	31.220
832B/BF36S	19	557	.18	2.8	557	.03	21	33.986
842B/BF36S	19	1457	.44	2.8	1457	.06	29	36.292
862B/BF36S	19	3120	.99	2.8	3120	.14	51	35.249
872B/BF36S	19	5296	1.74	2.8	5296	.25	99	34.208
833B/BF36S	19	562	.18	2.8	562	.03	29	35.393
843B/BF36S	19	1390	.45	2.8	1380	.07	37	35.193
863B/BF36S	19	2977	.97	2.8	2977	.14	59	35.059
873B/BF36S	19	5225	1.71	2.8	5225	.25	114	34.934
832B/BF40S	17	485	.15	2.5	485	.02	21	37.438
842B/BF40S	17	1254	.40	2.5	1254	.06	29	36.292
862B/BF40S	17	2930	.89	2.5	2930	.13	51	38.753
872B/BF40S	17	5050	1.54	2.5	5050	.22	99	38.150
833B/BF40S	17	562	.16	2.5	562	.02	29	40.446
843B/BF40S	17	1390	.39	2.5	1390	.06	37	40.216
863B/BF40S	17	2972	.85	2.5	2978	.12	59	39.830
873B/BF40S	17	5225	1.47	2.5	5225	.22	114	40.631

\* For applications requiring a service factor greater than 1.0, multiply the design torque or horsepower by the application factor, found on pages 344-345.

Actual Output RPM = Input Speed ÷ Actual Ratio.

For Overhung Load Ratings refer to Page 141.

Indicates Triple Reduction

# 800 SERIES RATIO AND CAPACITY SELECTION TABLES

Non-Flanged  
Input Speeds 1750 RPM, 1450 RPM & 1160 RPM

Service Factor 1.0\*

Catalog Number	Input Speed								
	1750 RPM			1450 RPM			1160 RPM		
	Approx. Output RPM	Output Torque (LB-IN)(Max.)	Input HP (Max.)	Approx. Output RPM	Output Torque (LB-IN)(Max.)	Input HP (Max.)	Approx. Output RPM	Output Torque (LB-IN) (Max.)	Input HP (Max.)
832B/BF45S	38	480	0.33	32	480	0.28	25	480	0.23
842B/BF45S	38	1410	0.90	32	1410	0.76	25	1450	0.61
862B/BF45S	38	2950	2.01	32	3010	1.70	25	3090	1.39
872B/BF45S	38	5167	3.54	32	5215	2.99	25	5254	2.41
833B/BF45S	38	544	0.38	32	540	0.31	25	540	0.25
843B/BF45S	38	1420	0.92	32	1420	0.76	25	1420	0.61
863B/BF45S	38	3040	2.01	32	3040	1.66	25	3040	1.33
873B/BF45S	38	5300	3.52	32	5300	2.91	25	5300	2.33
832B/BF50S	35	555	0.34	29	536	0.28	23	536	0.22
842B/BF50S	35	1500	0.87	29	1453	0.72	23	1500	0.58
862B/BF50S	35	3150	1.86	29	3150	1.55	23	3150	1.24
872B/BF50S	35	5216	3.16	29	5250	2.66	23	5250	2.10
833B/BF50S	35	540	0.33	29	540	0.27	23	540	0.22
843B/BF50S	35	1429	0.81	29	1429	0.67	23	1429	0.54
863B/BF50S	35	3040	1.77	29	3040	1.46	23	3040	1.17
873B/BF50S	35	5290	3.02	29	5290	2.50	23	5290	2.00
832B/BF56S	31	540	0.29	25	540	0.25	20	540	0.20
842B/BF56S	31	1392	0.71	25	1400	0.60	20	1400	0.49
862B/BF56S	31	2460	1.28	25	2460	1.06	20	2460	0.85
872B/BF56S	31	4629	2.50	25	4647	2.10	20	4700	1.70
833B/BF56S	31	554	0.30	25	540	0.25	20	540	0.20
843B/BF56S	31	1396	0.76	25	1396	0.63	20	1396	0.50
863B/BF56S	31	2887	1.54	25	2987	1.27	20	2987	1.01
873B/BF56S	31	5227	2.69	25	5227	2.23	20	5227	1.78
832B/BF63S	27	500	0.25	23	480	0.20	18	480	0.16
842B/BF63S	27	1475	0.70	23	1475	0.58	18	1425	0.45
862B/BF63S	27	3098	1.52	23	3120	1.29	18	3138	1.02
872B/BF63S	27	5300	2.64	23	5300	2.18	18	5300	1.75
833B/BF63S	27	522	0.26	23	530	0.22	18	530	0.17
843B/BF63S	27	1300	0.65	23	1300	0.54	18	1300	0.43
863B/BF63S	27	2973	1.41	23	2973	1.17	18	2973	0.94
873B/BF63S	27	5226	2.52	23	5228	2.09	18	5228	1.67
832B/BF71S	24	500	0.22	20	500	0.18	16	500	0.15
842B/BF71S	24	1485	0.62	20	1485	0.51	16	1485	0.41
862B/BF71S	24	2966	1.28	20	2966	1.06	16	2966	0.85
872B/BF71S	24	5385	2.38	20	5385	1.97	16	5385	1.58
833B/BF71S	24	577	0.24	20	577	0.20	16	577	0.16
843B/BF71S	24	1427	0.60	20	1427	0.50	16	1427	0.40
863B/BF71S	24	3040	1.23	20	3040	1.02	16	3040	0.81
873B/BF71S	24	5298	2.14	20	5298	1.77	16	5298	1.42

\* For applications requiring a service factor greater than 1.0, multiply the design torque or horsepower by the application factor, found on pages 344-345.

Actual Output RPM = Input Speed ÷ Actual Ratio.

For Overhung Load Ratings refer to Page 141.

Indicates Triple Reduction

# 800 SERIES RATIO AND CAPACITY SELECTION TABLES

Non-Flanged  
Input Speeds 690 RPM, & 100 RPM

Service Factor 1.0\*

Catalog Number	Input Speed						Approx. Wt. (LB)	Actual Gear Ratio
	690 RPM			100 RPM				
	Approx. Output RPM	Output Torque (LB-IN)(Max.)	Input HP (Max.)	Approx. Output RPM	Output Torque (LB-IN)(Max.)	Input HP (Max.)		
832B/BF45S	15	480	.13	2.2	480	.02	21	41.599
842B/BF45S	15	1450	.36	2.2	1450	.05	29	45.591
862B/BF45S	15	3090	.82	2.2	3090	.12	51	42.431
872B/BF45S	15	5254	1.41	2.2	5254	.20	99	41.802
833B/BF45S	15	580	.15	2.2	540	.02	29	42.354
843B/BF45S	15	1420	.36	2.2	1420	.05	37	45.630
863B/BF45S	15	3040	.78	2.2	3040	.12	59	44.706
873B/BF45S	15	5300	1.38	2.2	5300	.20	114	44.521
832B/BF50S	14	536	.13	2.0	536	.02	21	46.910
842B/BF50S	14	1500	.34	2.0	1500	.05	29	49.414
862B/BF50S	14	3150	.73	2.0	3150	.10	51	48.501
872B/BF50S	14	5250	1.26	2.0	5250	.18	99	47.276
833B/BF50S	14	540	.12	2.0	540	.02	29	48.400
843B/BF50S	14	1429	.32	2.0	1429	.04	37	52.143
863B/BF50S	14	3040	.70	2.0	3040	.10	59	50.789
873B/BF50S	14	5290	1.19	2.0	5290	.17	114	51.776
832B/BF56S	12	540	.12	2.0	540	.02	21	53.312
842B/BF56S	12	1400	.28	2.0	1400	.04	29	56.158
862B/BF56S	12	2460	.50	2.0	2460	.07	51	55.125
872B/BF56S	12	4700	1.01	2.0	4700	.15	99	53.029
833B/BF56S	12	540	.12	2.0	540	.02	29	54.596
843B/BF56S	12	1396	.30	2.0	1396	.04	37	54.281
863B/BF56S	12	2987	.59	2.0	2987	.09	59	57.321
873B/BF56S	12	5227	1.06	2.0	5227	.15	114	57.422
832B/BF63S	11	480	.009	1.6	480	.01	21	57.390
842B/BF63S	11	1475	.28	1.6	1475	.04	29	60.380
862B/BF63S	11	3138	.61	1.6	3138	.09	51	58.384
872B/BF63S	11	5300	1.03	1.6	5300	.15	99	57.770
833B/BF63S	11	570	.11	1.6	530	.01	29	59.396
843B/BF63S	11	1300	.26	1.6	1300	.04	37	59.054
863B/BF63S	11	2973	.54	1.6	2973	.08	59	62.319
873B/BF63S	11	5226	.98	1.6	5228	.14	114	61.309
832B/BF71S	10	500	.09	1.4	500	.01	21	65.190
842B/BF71S	10	1485	.25	1.4	1485	.03	29	68.619
862B/BF71S	10	2966	.50	1.4	2966	.07	51	66.358
872B/BF71S	10	5385	.94	1.4	5385	.13	99	64.801
833B/BF71S	10	577	.09	1.4	577	.01	29	71.078
843B/BF71S	10	1427	.23	1.4	1427	.03	37	70.302
863B/BF71S	10	3040	.47	1.4	3040	.07	59	73.093
873B/BF71S	10	5298	.85	1.4	5298	.13	114	73.172

\* For applications requiring a service factor greater than 1.0, multiply the design torque or horsepower by the application factor, found on pages 344-345.

Actual Output RPM = Input Speed ÷ Actual Ratio.

For Overhung Load Ratings refer to Page 141.

Indicates Triple Reduction

# 800 SERIES RATIO AND CAPACITY SELECTION TABLES

Non-Flanged  
Input Speeds 1750 RPM, 1450 RPM & 1160 RPM

Service Factor 1.0\*

Catalog Number	Input Speed								
	1750 RPM			1450 RPM			1160 RPM		
	Approx. Output RPM	Output Torque (LB-IN)(Max.)	Input HP (Max.)	Approx. Output RPM	Output Torque (LB-IN)(Max.)	Input HP (Max.)	Approx. Output RPM	Output Torque (LB-IN) (Max.)	Input HP (Max.)
833B/BF80S	21	565	0.21	18	565	0.17	14	565	0.14
843B/BF80S	21	1320	0.51	18	1320	0.42	14	1320	0.34
863B/BF80S	21	3038	1.13	18	3038	0.94	14	3038	0.75
873B/BF80S	21	5315	2.01	18	5315	1.66	14	5315	1.33
833B/BF90S	19	575	0.19	16	575	0.15	12	575	0.12
843B/BF90S	19	1395	0.47	16	1395	0.39	12	1395	0.31
863B/BF90S	19	2745	0.98	16	2745	0.82	12	2745	0.65
873B/BF90S	19	5252	1.73	16	5252	1.43	12	5252	1.14
833B/BF100S	17	570	0.17	14	575	0.14	11	575	0.11
843B/BF100S	17	1400	0.42	14	1400	0.35	11	1400	0.28
863B/BF100S	17	3095	0.88	14	3095	0.72	11	3095	0.58
873B/BF100S	17	5252	1.58	14	5252	1.31	11	5252	1.05
833B/BF112S	15	543	0.15	12	540	0.12	10	540	0.10
843B/BF112S	15	1340	0.37	12	1340	0.30	10	1340	0.24
863B/BF112S	15	2820	0.79	12	2820	0.65	10	2820	0.52
873B/BF112S	15	5300	1.37	12	5300	1.14	10	5300	0.91
833B/BF125S	14	523	0.13	11	520	0.11	9.3	520	0.09
843B/BF125S	14	1430	0.33	11	1430	0.27	9.3	1430	0.22
863B/BF125S	14	3000	0.70	11	3000	0.58	9.3	3000	0.46
873B/BF125S	14	5337	1.26	11	5337	1.04	9.3	5337	0.83
833B/BF140S	12	487	0.11	10	487	0.09	8.3	467	0.08
843B/BF140S	12	1360	0.29	10	1360	0.24	8.3	1360	0.20
863B/BF140S	12	2916	0.65	10	2916	0.54	8.3	2916	0.43
873B/BF140S	12	5247	1.11	10	5247	0.92	8.3	5247	0.74
833B/BF160S	10	490	0.10	9.1	490	0.09	7.2	490	0.07
843B/BF160S	10	1410	0.27	9.1	1410	0.22	7.2	1410	0.18
863B/BF160S	10	3130	0.58	9.1	3130	0.48	7.2	3130	0.39
873B/BF160S	10	5280	1.02	9.1	5280	0.84	7.2	5280	0.67
833B/BF180S	9.7	555	0.10	8.0	555	0.08	6.4	555	0.06
843B/BF180S	9.7	1436	0.24	8.0	1436	0.20	6.4	1436	0.16
863B/BF180S	9.7	3146	0.53	8.0	3148	0.44	6.4	3148	0.35
873B/BF180S	9.7	5362	0.92	8.0	5362	0.76	6.4	5362	0.61
833B/BF200S	8.8	568	0.09	7.3	555	0.07	5.8	555	0.06
843B/BF200S	8.8	1428	0.21	7.3	1428	0.17	5.8	1428	0.14
863B/BF200S	8.8	3173	0.47	7.3	3173	0.39	5.8	3173	0.31
873B/BF200S	8.8	5432	0.82	7.3	5432	0.68	5.8	5432	0.55
833B/BF225S	7.8	544	0.08	6.4	544	0.07	5.2	544	0.05
843B/BF225S	7.8	1410	0.19	6.4	1410	0.16	5.2	1410	0.13
863B/BF225S	7.8	3146	0.44	6.4	3146	0.36	5.2	3146	0.29
873B/BF225S	7.8	5341	0.75	6.4	5341	0.62	5.2	5341	0.50
833B/BF250S	7.0	540	0.07	5.8	540	0.06	4.6	540	0.05
843B/BF250S	7.0	1410	0.17	5.8	1410	0.14	4.6	1410	0.11
863B/BF250S	7.0	3110	0.39	5.8	3110	0.32	4.6	3110	0.26
873B/BF250S	7.0	5423	0.67	5.8	5423	0.56	4.6	5423	0.45

\* For applications requiring a service factor greater than 1.0, multiply the design torque or horsepower by the application factor, found on pages 344-345.

Actual Output RPM = Input Speed ÷ Actual Ratio.

For Overhung Load Ratings refer to Page 141.

■ Indicates Triple Reduction

# 800 SERIES RATIO AND CAPACITY SELECTION TABLES

Non-Flanged  
Input Speeds 690 RPM, & 100 RPM

Service Factor 1.0\*

Catalog Number	Input Speed						Approx. Wt. (LB)	Actual Gear Ratio
	690 RPM			100 RPM				
	Approx. Output RPM	Output Torque (LB-IN)(Max.)	Input HP (Max.)	Approx. Output RPM	Output Torque (LB-IN)(Max.)	Input HP (Max.)		
833B/BF80S	8.6	565	.08	1.25	565	.01	29	79.506
843B/BF80S	8.6	1320	.19	1.25	1320	.03	37	76.483
863B/BF80S	8.6	3038	.43	1.25	3038	.06	59	79.466
873B/BF80S	8.6	5315	.77	1.25	5315	.11	114	78.141
833B/BF90S	7.7	575	.07	1.25	575	.01	29	89.460
843B/BF90S	7.7	1395	.18	1.25	1395	.03	37	87.686
863B/BF90S	7.7	2745	.38	1.25	2745	.05	59	82.764
873B/BF90S	7.7	5252	.66	1.25	5252	.10	114	89.712
833B/BF100S	6.9	575	.06	1.25	575	.01	29	99.401
843B/BF100S	6.9	1400	.16	1.25	1400	.02	37	98.820
863B/BF100S	6.9	3095	.33	1.25	3095	.05	59	103.962
873B/BF100S	6.9	5252	.61	1.25	5252	.09	114	98.233
833B/BF112S	6.2	540	.06	.89	540	.01	29	107.054
843B/BF112S	6.2	1340	.14	.89	1340	.02	37	113.691
863B/BF112S	6.2	2820	.30	.89	2820	.04	59	105.536
873B/BF112S	6.2	5300	.53	.89	5300	.08	114	114.319
833B/BF125S	5.5	520	.05	.80	520	.01	29	118.950
843B/BF125S	5.5	1430	.13	.80	1430	.02	37	128.128
863B/BF125S	5.5	3000	.27	.80	3000	.04	59	127.052
873B/BF125S	5.5	5337	.48	.80	5337	.07	114	125.178
833B/BF140S	5.0	487	.05	.71	487	.01	29	131.034
843B/BF140S	5.0	1360	.11	.71	1360	.02	37	138.931
863B/BF140S	5.0	2916	.25	.71	2916	.04	59	132.567
873B/BF140S	5.0	5247	.43	.71	5247	.06	114	139.695
833B/BF160S	4.3	490	.04	.62	490	.01	29	145.595
843B/BF160S	4.3	1410	.10	.62	1410	.01	37	156.574
863B/BF160S	4.3	3130	.22	.62	3130	.03	59	159.582
873B/BF160S	4.3	5280	.40	.62	5280	.06	114	152.964
833B/BF180S	3.8	555	.04	.55	555	.01	29	164.184
843B/BF180S	3.8	1436	.09	.55	1436	.01	37	176.854
863B/BF180S	3.8	3148	.20	.55	3148	.03	59	175.553
873B/BF180S	3.8	5362	.36	.55	5362	.05	114	172.231
833B/BF200S	3.4	555	.03	.50	555	.01	29	186.590
843B/BF200S	3.4	1428	.08	.50	1428	.01	37	200.989
863B/BF200S	3.4	3173	.18	.50	3173	.03	59	199.528
873B/BF200S	3.4	5432	.33	.50	5432	.05	114	195.757
833B/BF225S	3.1	544	.03	.44	544	.01	29	200.962
843B/BF225S	3.1	1410	.07	.44	1410	.01	37	216.098
863B/BF225S	3.1	3146	.17	.44	3146	.02	59	211.326
873B/BF225S	3.1	5341	.29	.44	5341	.41	114	210.462
833B/BF250S	2.76	540	.03	.40	540	.01	29	228.387
843B/BF250S	2.76	1410	.06	.40	1410	.01	37	245.633
863B/BF250S	2.76	3110	.15	.40	3110	.02	59	240.188
873B/BF250S	2.76	5423	.26	.40	5423	.04	114	239.210

\* For applications requiring a service factor greater than 1.0, multiply the design torque or horsepower by the application factor, found on pages 344-345.

Actual Output RPM = Input Speed ÷ Actual Ratio.

For Overhung Load Ratings refer to Page 141.

Indicates Triple Reduction

# 800 SERIES IN-LINE HELICAL GEAR DRIVES DIMENSIONS

## FOOT MOUNTED

## F800B SERIES DOUBLE REDUCTION NEMA C-FACE INPUT

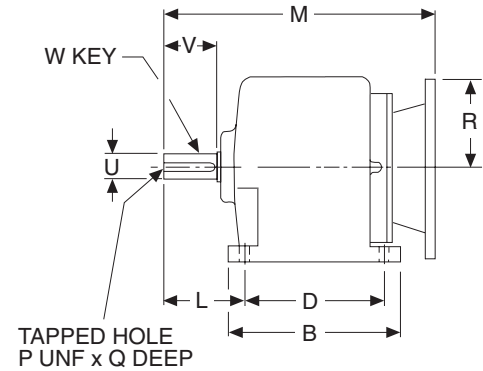
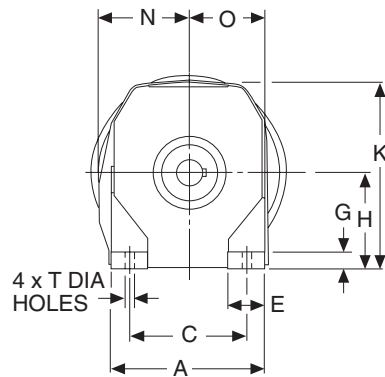

SIZE	A	B	C	D	E	G	H	K	L	N	O	P	Q	T
F832B	5.44	4.33	4.33	3.35	1.05	.48	2.95	5.79	2.28	3.16	2.84	1/4	.63	.39
F842B	5.71	6.30	4.33	5.12	1.48	.67	3.54	6.99	2.95	3.31	2.95	1/4	.63	.39
F862B	7.48	7.87	5.31	6.50	2.19	.81	4.53	9.06	3.54	4.13	3.87	3/8	.87	.59
F872B	9.06	9.65	6.69	8.07	2.64	1.03	5.51	10.83	4.53	5.12	4.69	5/8	1.38	.75

SIZE	LOW SPEED SHAFT				M				R			
	U +.000 -.001	V	W-Key		NEMA MOUNTING				NEMA MOUNTING			
			Sq.	Lgth.	56C	140TC	180TC	210TC	56C	140TC	180TC	210TC
					B5	B7	B9	B11	B5	B7	B9	B11
F832B	.750	1.57	.19	1.28	9.82	9.82	10.65	----	3.31	3.31	4.63	----
F842B	1.000	1.97	.25	1.75	10.73	10.73	11.55	----	3.31	3.31	4.63	----
F862B	1.250	2.36	.25	2.00	12.26	12.26	14.61	14.61	3.31	3.31	4.63	4.63
F872B	1.625	3.15	.38	2.37	15.15	15.15	16.76	16.76	3.31	3.31	4.63	4.63

Output shaft rotation, relative to input shaft rotation, is identical for double reduction and opposite for triple reduction.

# 800 SERIES IN-LINE HELICAL GEAR DRIVES DIMENSIONS

## FOOT MOUNTED

## F800B SERIES TRIPLE REDUCTION NEMA C-FACE INPUT

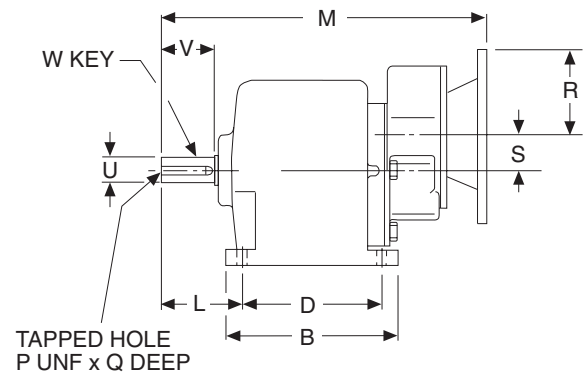
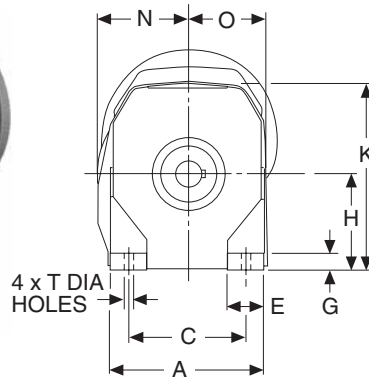

SIZE	A	B	C	D	E	G	H	K	L	N	O	P	Q	S
F833B	5.44	4.33	4.33	3.35	1.05	.48	2.95	5.79	2.28	3.16	2.84	1/4	.63	1.40
F843B	5.71	6.30	4.33	5.12	1.48	.67	3.54	6.99	2.95	3.31	2.95	1/4	.63	1.40
F863B	7.48	7.87	5.31	6.50	2.19	.81	4.53	9.06	3.54	4.13	3.87	3/8	.87	1.83
F873B	9.06	9.65	6.69	8.07	2.64	1.03	5.51	10.83	4.53	5.12	4.69	5/8	1.38	2.34

SIZE	T	LOW SPEED SHAFT				M			R		
		U +.000 -.001	V	W-Key		NEMA MOUNTING			NEMA MOUNTING		
				Sq.	Lgth.	56C	140TC	180TC	56C	140TC	180TC
						B5	B7	B9	B5	B7	B9
F833B	.39	.750	1.57	.19	1.28	12.03	----	----	3.31	----	----
F843B	.39	1.000	1.97	.25	1.75	12.94	----	----	3.31	----	----
F863B	.59	1.250	2.36	.25	2.00	15.38	15.38	----	3.31	3.31	----
F873B	.75	1.625	3.15	.38	2.37	18.28	18.28	20.63	3.31	3.31	4.63

Output shaft rotation, relative to input shaft rotation, is identical for double reduction and opposite for triple reduction.

# 800 SERIES IN-LINE HELICAL GEAR DRIVES DIMENSIONS

## OUTPUT FLANGE MOUNTED

## F800BF SERIES DOUBLE REDUCTION NEMA C-FACE INPUT

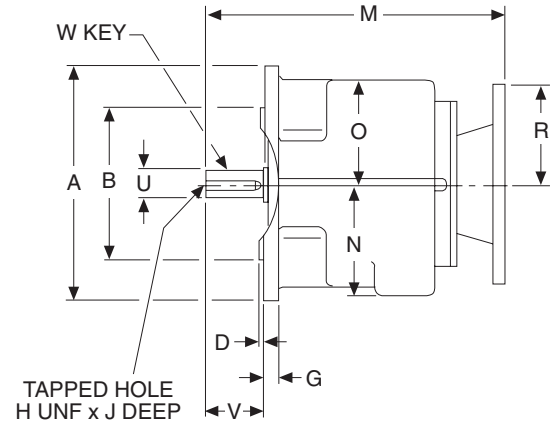
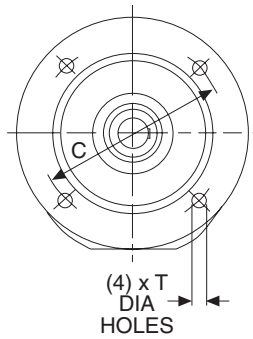

SIZE	A	B +.000 -.003	C	D	G	H	J	N	O	T
F832BF	6.30	4.330	5.12	.14	.28	1/4	.63	3.15	2.76	.39
F842BF	7.87	5.118	6.50	.14	.47	1/4	.63	3.74	3.46	.47
F862BF	9.84	7.086	8.46	.16	.47	3/8	.87	4.45	4.53	.59
F872BF	11.81	9.055	10.43	.16	.55	5/8	1.38	5.43	5.43	.59

SIZE	LOW SPEED SHAFT				M				R			
	U +.000 -.001	V	W-Key		NEMA MOUNTING				NEMA MOUNTING			
			Sq.	Lgth.	56C	140TC	180TC	210TC	56C	140TC	180TC	210TC
					B5	B7	B9	B11	B5	B7	B9	B11
F832BF	.750	1.57	.19	1.28	9.82	9.82	10.65	----	3.31	3.31	4.63	----
F842BF	1.000	1.97	.25	1.75	10.73	10.73	11.55	----	3.31	3.31	4.63	----
F862BF	1.250	2.36	.25	2.00	12.26	12.26	14.61	14.61	3.31	3.31	4.63	4.63
F872BF	1.625	3.15	.38	2.37	15.15	15.15	16.76	16.76	3.31	3.31	4.63	4.63

Output shaft rotation, relative to input shaft rotation, is identical for double reduction and opposite for triple reduction.

# 800 SERIES IN-LINE HELICAL GEAR DRIVES DIMENSIONS

## OUTPUT FLANGE MOUNTED

## F800BF SERIES TRIPLE REDUCTION NEMA C-FACE INPUT

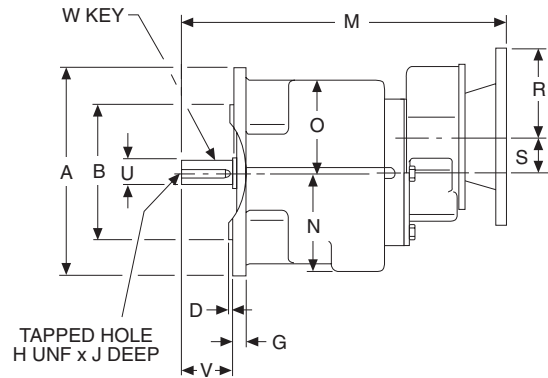
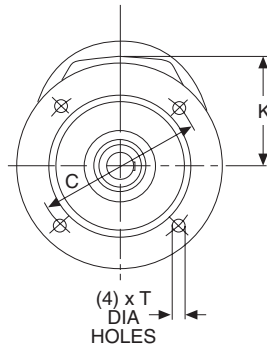
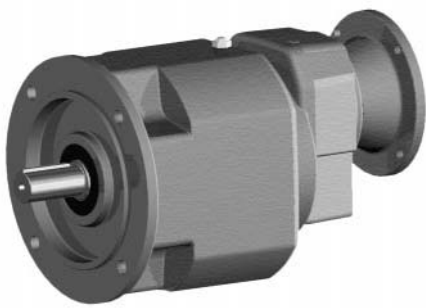

SIZE	A	B +.000 -.003	C	D	G	H	J	K	N	O	S
F833BF	6.30	4.330	5.12	.14	.28	1/4	.63	4.17	3.15	2.76	1.40
F843BF	7.87	5.118	6.50	.14	.47	1/4	.63	4.17	3.74	3.46	1.40
F863BF	9.84	7.086	8.46	.16	.47	3/8	.87	4.45	4.45	4.53	1.83
F873BF	11.81	9.055	10.43	.16	.55	5/8	1.38	5.43	5.43	5.43	2.34

SIZE	T	LOW SPEED SHAFT				M			R		
		U +.000 -.001	V	W-Key		NEMA MOUNTING			NEMA MOUNTING		
				Sq.	Lgth.	56C B5	140TC B7	180TC B9	56C B5	140TC B7	180TC B9
F833BF	.39	.750	1.57	.19	1.28	12.03	----	----	3.31	----	----
F843BF	.47	1.000	1.97	.25	1.75	12.94	----	----	3.31	----	----
F863BF	.59	1.250	2.36	.25	2.00	15.38	15.38	----	3.31	3.31	----
F873BF	.59	1.625	3.15	.38	2.37	18.28	18.28	20.63	3.31	3.31	4.63

Output shaft rotation, relative to input shaft rotation, is identical for double reduction and opposite for triple reduction.

# 800 SERIES IN-LINE HELICAL GEAR DRIVES DIMENSIONS

## FOOT MOUNTED

## 800B SERIES DOUBLE REDUCTION NON-FLANGED

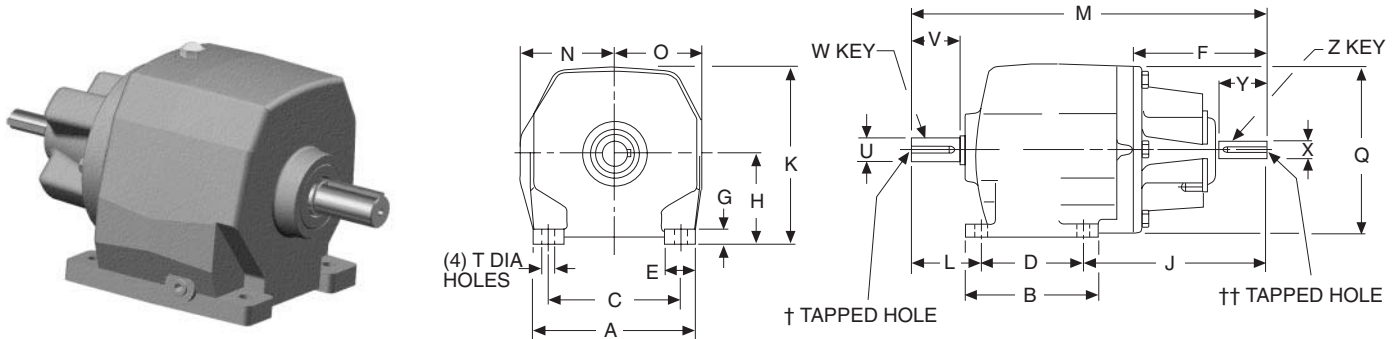

SIZE	A	B	C	D	E	F	G	H	J	K	L	M	N
832B	5.44	4.33	4.33	3.35	1.05	4.37	.48	2.95	5.94	5.79	2.28	11.57	3.16
842B	5.71	6.30	4.33	5.12	1.48	4.37	.67	3.54	4.41	6.99	2.95	12.48	3.31
862B	7.48	7.87	5.31	6.50	2.19	4.37	.81	4.53	4.49	9.06	3.54	14.53	4.13
872B	9.06	9.65	6.69	8.07	2.64	4.53	1.03	5.51	4.72	10.83	4.53	17.32	5.12

SIZE	O	Q	T	LOW SPEED SHAFT				HIGH SPEED SHAFT			
				U +.000 -.001	V	W-Key		X +.000 -.001	Y	Z-Key	
						Sq.	Lgth.			Sq.	Lgth.
832B	2.84	5.51	.39	.750	1.57	.19	1.28	.625	1.57	.19	1.28
842B	2.95	5.51	.39	1.000	1.97	.25	1.75	.625	1.57	.19	1.28
862B	3.87	7.09	.59	1.250	2.36	.25	2.00	.750	1.57	.19	1.28
872B	4.69	8.46	.75	1.625	3.15	.38	2.37	.875	1.97	.19	1.28

Output shaft rotation, relative to input shaft rotation, is identical for double reduction and opposite for triple reduction.

† 832B 1/4 UNF x 0.63 DP, 842B 1/4UNF x 0.63 DP. Size 862B 3/8 UNF x 0.87 DP. Size 872B 5/8 UNF x 1.38 DP.  
 †† 832B 1/4 UNF x 0.49 DP, 842B 1/4 UNF x 0.49 DP. Size 862B 1/4 UNF x 0.63 DP. Size 872B 5/16 UNF x 0.63 DP.

# 800 SERIES IN-LINE HELICAL GEAR DRIVES DIMENSIONS

## FOOT MOUNTED

## 800B SERIES TRIPLE REDUCTION NON-FLANGED

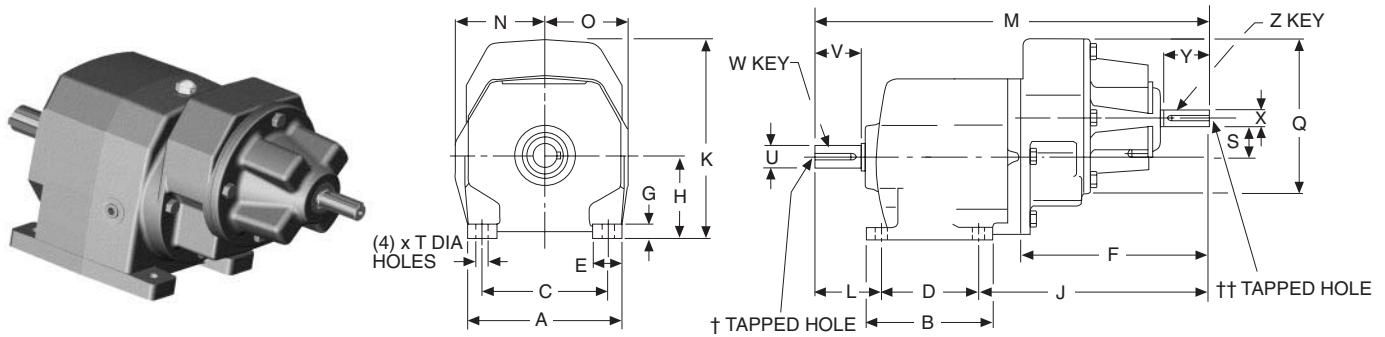

SIZE	A	B	C	D	E	F	G	H	J	K	L	M	N
833B	5.44	4.33	4.33	3.35	1.05	6.57	.48	2.95	8.15	7.13	2.28	13.78	3.16
843B	5.71	6.30	4.33	5.12	1.48	6.57	.67	3.54	6.61	7.72	2.95	14.69	3.31
863B	7.48	7.87	5.31	6.50	2.19	6.97	.81	4.53	7.09	9.13	3.54	17.13	4.13
873B	9.06	9.65	6.69	8.07	2.64	7.76	1.03	5.51	7.95	11.42	4.53	20.55	5.12

SIZE	O	Q	S	T	LOW SPEED SHAFT				HIGH SPEED SHAFT			
					U +.000 -.001	V	W-Key		X +.000 -.001	Y	Z-Key	
							Sq.	Lgth.			Sq.	Lgth.
833B	2.84	5.51	1.40	.39	.750	1.57	.19	1.28	.625	1.57	.19	1.28
843B	2.95	5.51	1.40	.39	1.000	1.97	.25	1.75	.625	1.57	.19	1.28
863B	3.87	5.51	1.83	.59	1.250	2.36	.25	2.00	.625	1.57	.19	1.28
873B	4.69	7.09	2.34	.75	1.625	3.15	.38	2.37	.750	1.57	.19	1.28

Output shaft rotation, relative to input shaft rotation, is identical for double reduction and opposite for triple reduction.

† Size 833B 1/4 UNF x 0.63 DP, 843 1/4 UNF x 0.63 DP, 863B 3/8 UNF x 0.87 DP. Size 873B 5/8 UNF x 1.38 DP.

†† Size 833B 1/4 UNF x 0.49 DP, 843 1/4 UNF x 0.49 DP, 863B 1/4 UNF x 0.63 DP. Size 873B 5/16 UNF x 0.63 DP.

# 800 SERIES IN-LINE HELICAL GEAR DRIVES DIMENSIONS

## OUTPUT FLANGE MOUNTED

## 800BF SERIES DOUBLE REDUCTION NON-FLANGED

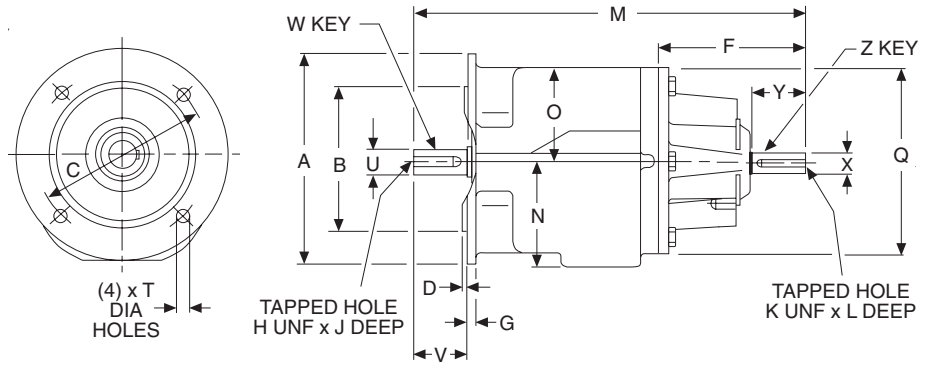
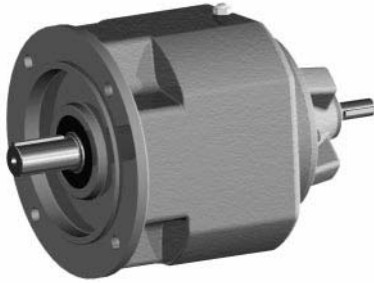

SIZE	A	B +.000 -.003	C	D	F	G	H	J	K	L	M	N
832BF	6.30	4.331	5.12	.14	4.37	.28	1/4	.63	1/4	.49	11.57	3.15
842BF	7.87	5.118	6.50	.14	4.37	.47	1/4	.63	1/4	.49	12.48	3.74
862BF	9.84	7.087	8.46	.16	4.37	.47	3/8	.87	1/4	.63	14.53	4.45
872BF	11.81	9.055	10.43	.16	4.53	.55	5/8	1.38	5/16	.63	17.32	5.43

SIZE	O	Q	T	LOW SPEED SHAFT				HIGH SPEED SHAFT			
				U +.000 -.001	V	W-Key		X +.000 -.001	Y	Z-Key	
						Sq.	Lgth.			Sq.	Lgth.
832BF	2.76	5.51	.39	.750	1.57	.19	1.28	.6250	1.57	.19	1.28
842BF	3.46	5.51	.47	1.000	1.97	.25	1.75	.6250	1.57	.19	1.28
862BF	4.53	7.09	.59	1.250	2.36	.25	2.00	.7500	1.57	.19	1.28
872BF	5.43	8.35	.59	1.625	3.15	.38	2.37	.8750	1.97	.19	1.28

Output shaft rotation, relative to input shaft rotation, is identical for double reduction and opposite for triple reduction.

# 800 SERIES IN-LINE HELICAL GEAR DRIVES DIMENSIONS

## OUTPUT FLANGE MOUNTED

## 800BF SERIES TRIPLE REDUCTION NON-FLANGED

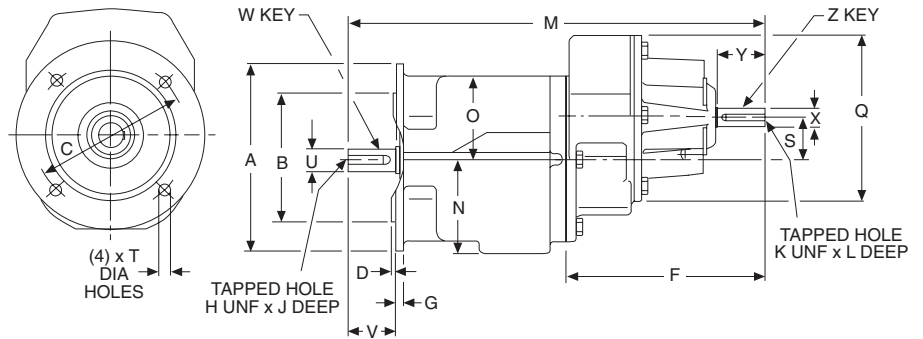

SIZE	A	B +.000 -.003	C	D	F	G	H	J	K	L	M	N
833BF	6.30	4.331	5.12	.14	6.57	.28	1/4	.63	1/4	.49	13.78	3.15
843BF	7.87	5.118	6.50	.14	6.57	.47	1/4	.63	1/4	.49	14.69	3.74
863BF	9.84	7.087	8.46	.16	6.97	.47	3/8	.87	1/4	.63	17.13	4.45
873BF	11.81	9.055	10.43	.16	7.76	.55	5/8	1.38	5/16	.63	20.55	5.43

SIZE	O	Q	S	T	LOW SPEED SHAFT				HIGH SPEED SHAFT			
					U +.000 -.001	V	W-Key		X +.000 -.001	Y	Z-Key	
							Sq.	Lgth.			Sq.	Lgth.
833BF	2.76	5.51	1.40	.39	.750	1.57	.19	1.28	.625	1.57	.19	1.28
843BF	3.46	5.51	1.40	.47	1.000	1.97	.25	1.75	.625	1.57	.19	1.28
863BF	4.53	5.51	1.83	.59	1.250	2.36	.25	2.00	.625	1.57	.19	1.28
873BF	5.43	7.09	2.34	.59	1.625	3.15	.38	2.37	.750	1.57	.19	1.28

Output shaft rotation, relative to input shaft rotation, is identical for double reduction and opposite for triple reduction.